

TOP VIEW
SCALE:1/16

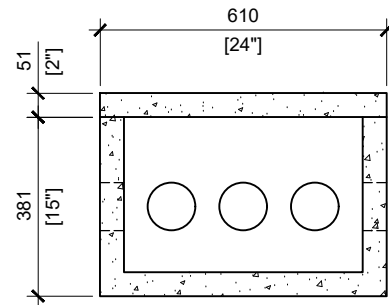

SECTION A
SCALE:1/16

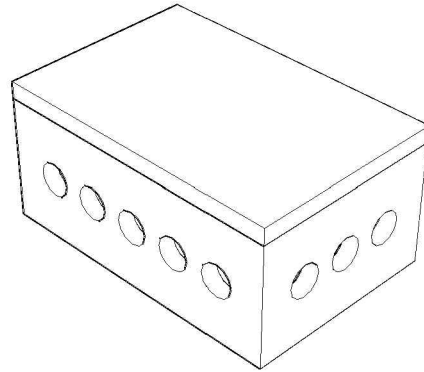
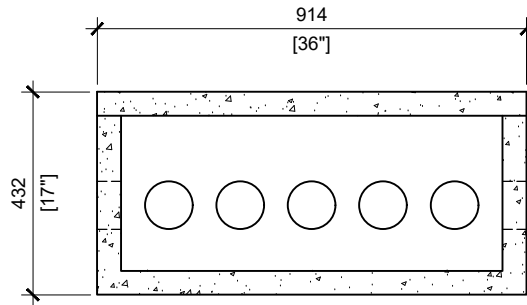

SECTION B
SCALE:1/16

LARGE DISTRIBUTION BOX

1 INLET - 15 OUTLET

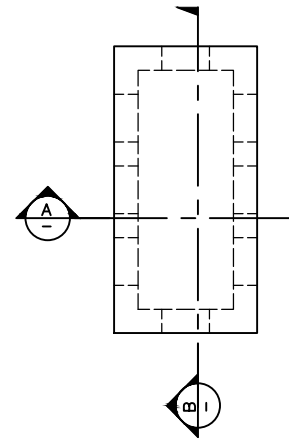

TOP VIEW
SCALE:1/16

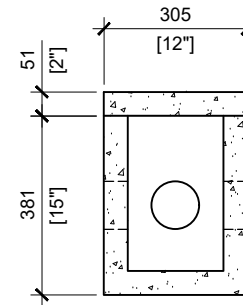
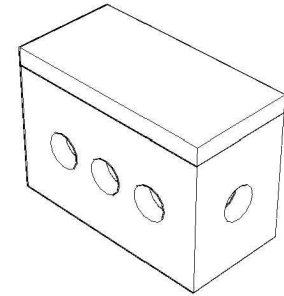

SECTION A
SCALE:1/16

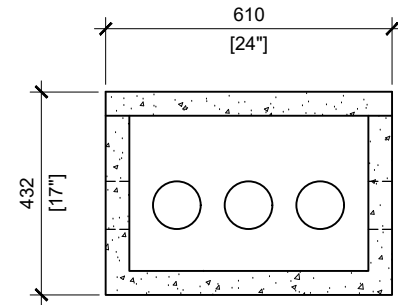

SECTION B
SCALE:1/16

SMALL DISTRIBUTION BOX

1 INLET - 7 OUTLET



MANUFACTURED:
BROOKLIN, ON
1-800-655-3430

CONCRETE: 35MPa/5000PSI
AIR ENTRAINMENT: 6-8%
REINFORCEMENT: STEEL TO CSA CAN
A23.1 /A23.3 G30.18 Fy=400MPa

UNIT WEIGHT:
LARGE: 515lbs / 234kg
SMALL: 226lbs / 103kg
CPA CERTIFIED
MEETS CAN/CSA-B66

DRAWN BY:
S.RIMLAND

DATE:
JAN/2019

DISTRIBUTION BOXES

LARGE & SMALL CONCRETE DISTRIBUTION BOXES