

SIDE VIEW
SCALE 1:16

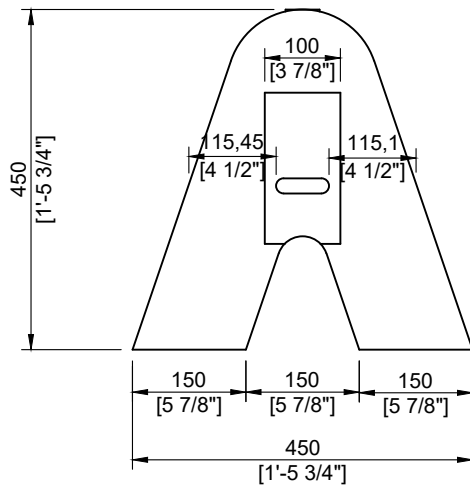

LEFT VIEW
SCALE 1:10

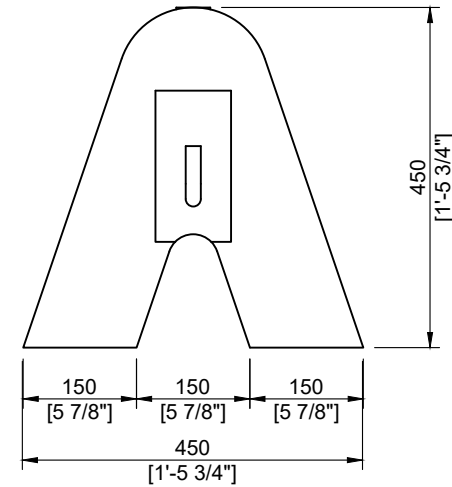
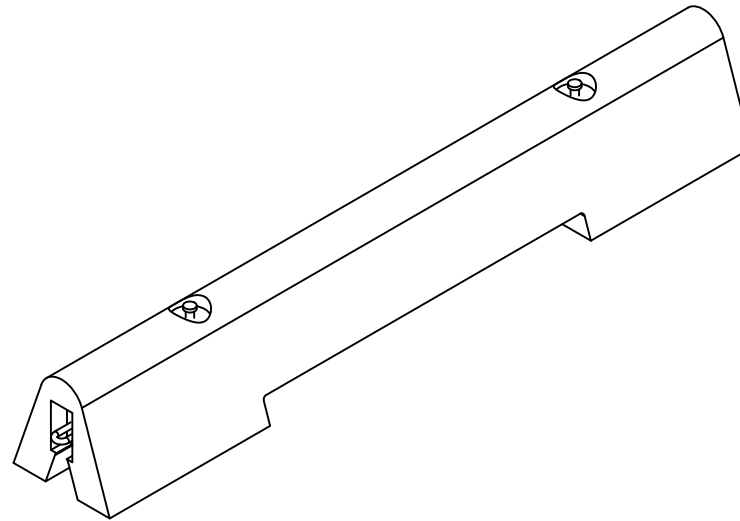

RIGHT VIEW
SCALE 1:10



MANUFACTURED:
OTTAWA, ON
613-822-1488

www.powerprecast.com

CONCRETE TYPE: SCC
CONCRETE: 45MPa / 6,526PSI
AIR CONTENT: 6.5% ± 1.5%
REINFORCEMENT: STEEL TO CSA CAN
A23.4-05 / A23.3. G30.18 Fy=400MPa

WEIGHT: 1,670lbs / 759kg
STRIPPING STRENGTH: 25 MPA

MANUFACTURED TO CSA A23.4

SHEET:
1/1

DWG NO.
B - 1.19

DRAWN BY:
A.A-Hamid

DATE:
JAN/2021

V-SHAPED PEDESTRIAN MINI BARRIER

PPS REFERENCE: 413703