

TOP VIEW
SCALE: 1/50

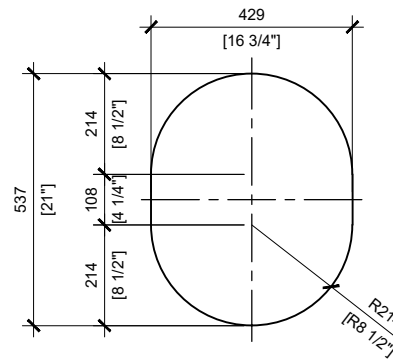

DETAIL 1
TOILET RISER OPENING
(TYP.)
SCALE: 1/16

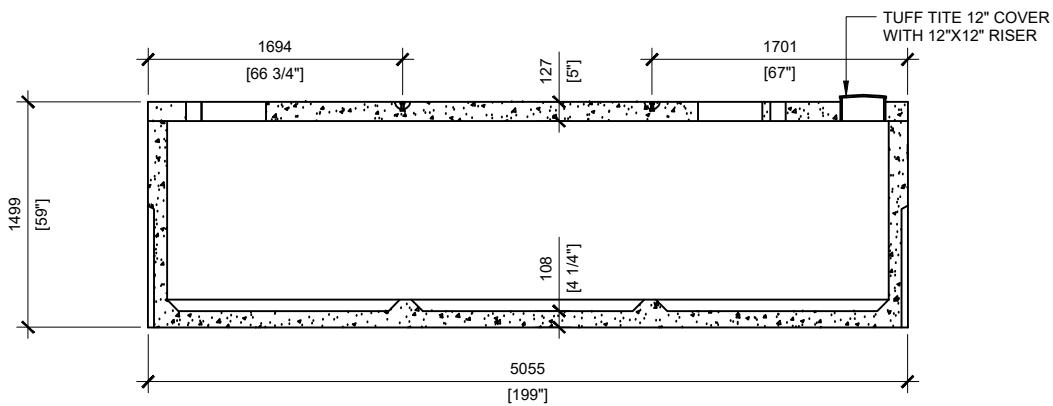

SECTION A
SCALE: 1/50

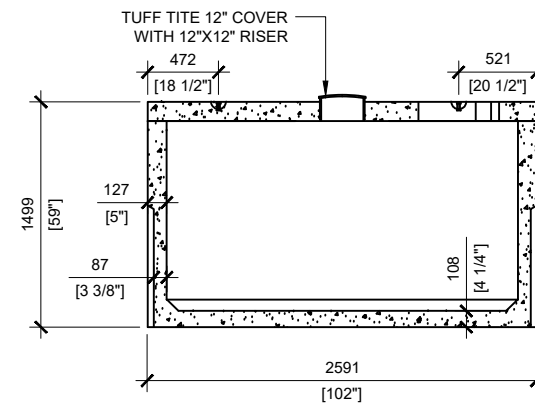

SECTION B
SCALE: 1/50

GENERAL NOTES:

1. UNITS ARE SEALED WITH BUTYL TAPE AT THE JOINTS
2. DELIVERY IS MADE BY CRANE-EQUIPPED TRUCKS
3. EXCAVATION MUST BE READY, SAFE AND ACCESSIBLE FOR UNLOADING FROM THE REAR OF THE TRUCK.
4. MIN OVERHEAD CLEARANCE OF 18FT (5.5 METRES) IS REQUIRED
5. ALL UNITS MUST BE HANDLED WITH PROPER LIFTING EQUIPMENT
6. MAXIMUM BURIAL DEPTH = 1 METRE IN FIRM SOIL AWAY FROM ANY VEHICULAR TRAFFIC



MANUFACTURED:
BROOKLIN, ON
1-800-655-3430

CONCRETE: 35MPa/5000PSI
AIR ENTRAINMENT: 5-8%
MEETS CAN/CSA-B66-00
REINFORCEMENT: STEEL TO CSA CAN
A23.1 /A23.3 G30.18 Fy=400MPa

WEIGHT: 27,180lbs / 12,330kg

DRAWN BY:
S.RIMLAND

DATE:
MAR/2021

PRIVY 11000 (WOOD STRUCTURE)

11,000 LITRES