

TOP VIEW
SCALE: 1/20

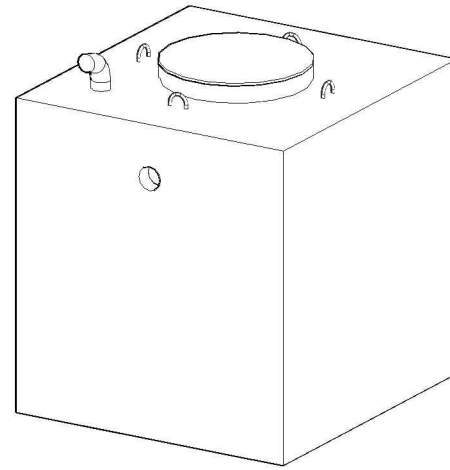

GENERAL NOTES:

1. UNITS ARE SEALED WITH BUTYL TAPE AT THE JOINTS
2. DELIVERY IS MADE BY CRANE-EQUIPPED TRUCKS
3. EXCAVATION MUST BE READY, SAFE AND ACCESSIBLE FOR UNLOADING FROM THE REAR OF THE TRUCK.
4. MIN OVERHEAD CLEARANCE OF 18FT (5.5 METRES) IS REQUIRED
5. ALL UNITS MUST BE HANDLED WITH PROPER LIFTING EQUIPMENT
6. MAXIMUM BURIAL DEPTH = 1 METRE IN FIRM SOIL AWAY FROM ANY VEHICULAR TRAFFIC
7. TUF-TITE SAFETY LID INSTALLED IN OPENING AS PER CSA-B66-21

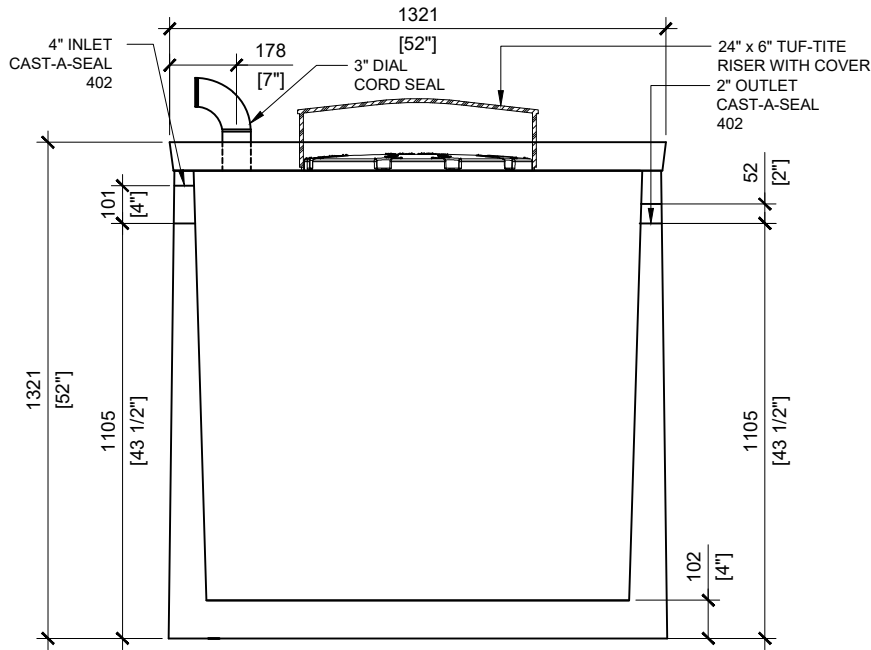

FRONT VIEW
SCALE: 1/20

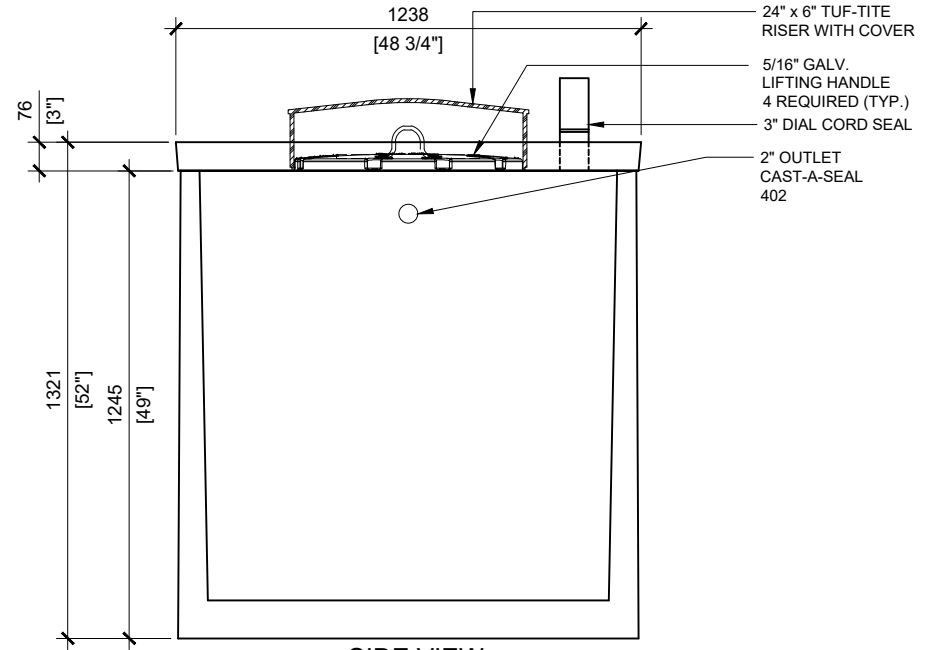

SIDE VIEW
SCALE: 1/20



MANUFACTURED:
BROOKLIN, ON
1-800-655-3430

CONCRETE: 35MPa/5000PSI
AIR ENTRAINMENT: 5-8%
REINFORCEMENT: STEEL TO CSA CAN
A23.1 /A23.3 G30.18 Fy=400MPa

WEIGHT:
1200 LITRES- 3,560 lbs / 1,615kg
CPA CERTIFIED
MEETS CAN/CSA-B66
"AGINP"

DRAWN BY:
JAY PATEL

1200 LITRES

**PUMP
TANK**

DATE:
MAR/2022

WORKING CAPACITY: 1,266L TO INVERT OF INLET
TOTAL CAPACITY: 1,442L TO UNDERSIDE OF CHAMBER LID