

TOP VIEW
SCALE:1/50

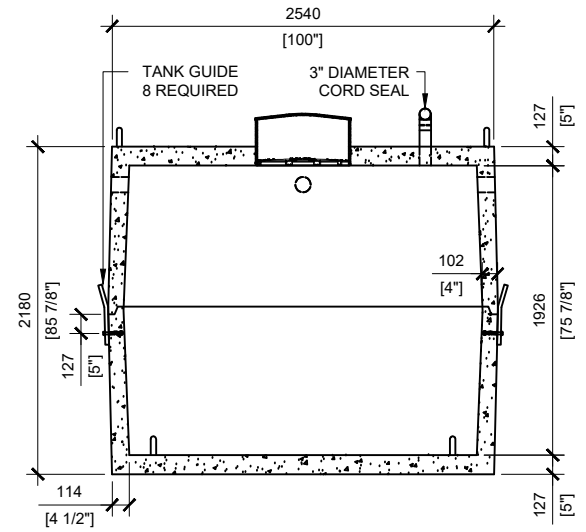

SECTION B
SCALE:1/50

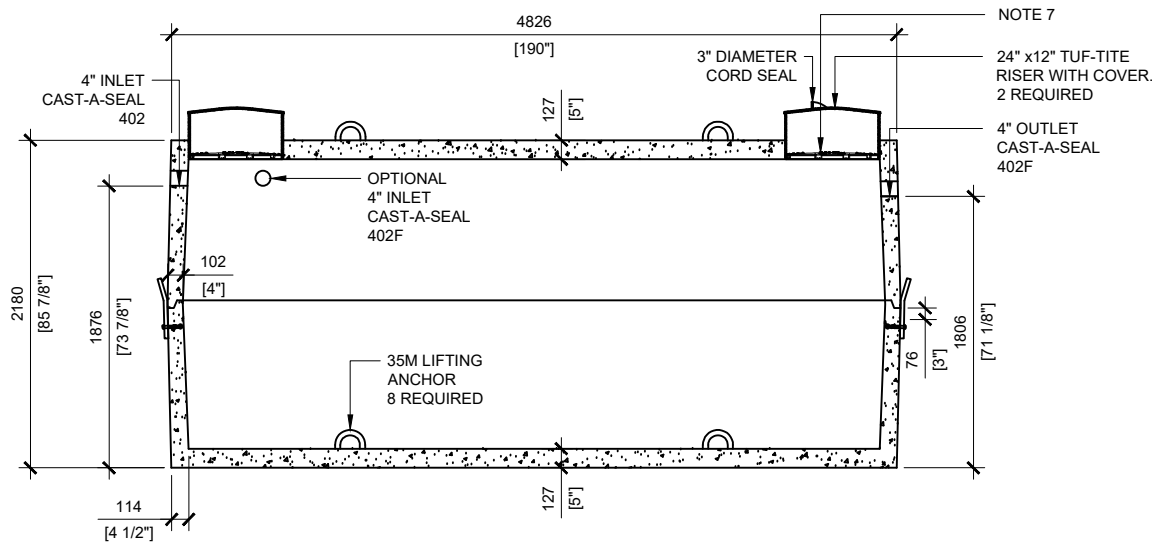

SECTION A
SCALE:1/50

GENERAL NOTES:

1. UNITS ARE SEALED WITH BUTYL TAPE AT THE JOINTS
2. DELIVERY IS MADE BY CRANE-EQUIPPED TRUCKS
3. EXCAVATION MUST BE READY FOR INSTALL
4. MIN OVERHEAD CLEARANCE OF 18FT (5.5 METRES) IS REQUIRED
5. ALL UNITS MUST BE HANDLED WITH PROPER LIFTING EQUIPMENT
6. MAXIMUM BURIAL DEPTH = 1 METRE IN FIRM SOIL AWAY FROM ANY VEHICULAR TRAFFIC
7. TUF-TITE SAFETY LIDS INSTALLED IN BOTH OPENINGS AS PER CSA-B66-21



MANUFACTURED:
OTTAWA, ON
1-800-655-3430

CONCRETE: 40MPa at 28 days / 5,800PSI
AIR ENTRAINMENT: 5-8%
REINFORCEMENT: STEEL TO CSA CAN
A23.1 /A23.3 G30.18 Fy=400MPa

APPROX. TOTAL UNIT WEIGHT:
36,398lbs / 16,509kg
CSA APPROVED
"AGINP"

DRAWN BY:
JAY PATEL

DATE:
APRIL/2022

18000 LITRES SINGLE CHAMBER

WORKING CAPACITY: 18,658L TO INVERT OF INLET
TOTAL CAPACITY: 20,492L TO UNDERSIDE OF CHAMBER LID