

TOP VIEW
SCALE:1/50

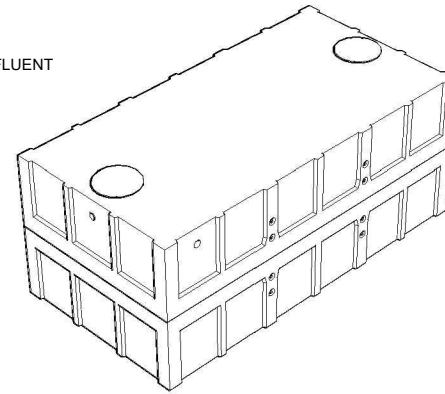

GENERAL NOTES:

1. UNITS ARE SEALED WITH BUTYL TAPE AT THE JOINTS
2. DELIVERY IS MADE BY CRANE-EQUIPPED TRUCKS
3. EXCAVATION MUST BE READY, SAFE AND ACCESSIBLE FOR UNLOADING FROM THE REAR OF THE TRUCK.
4. MIN OVERHEAD CLEARANCE OF 18FT IS REQUIRED
5. ALL UNITS MUST BE HANDLED WITH PROPER LIFTING EQUIPMENT (I.E. SPREADER BAR)
6. MAXIMUM BURIAL DEPTH = 1 METRE IN FIRM SOIL AWAY FROM ANY VEHICULAR TRAFFIC

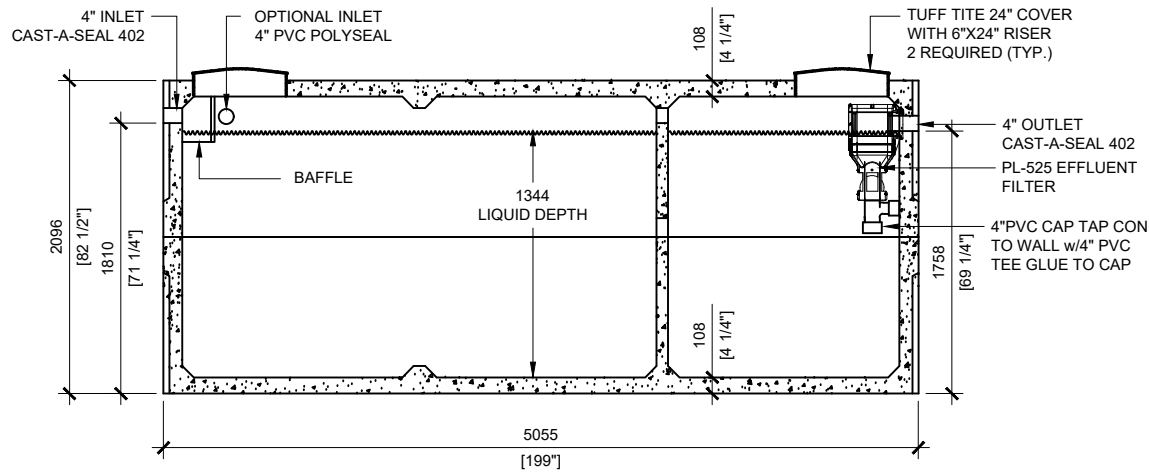

SECTION A
SCALE:1/50

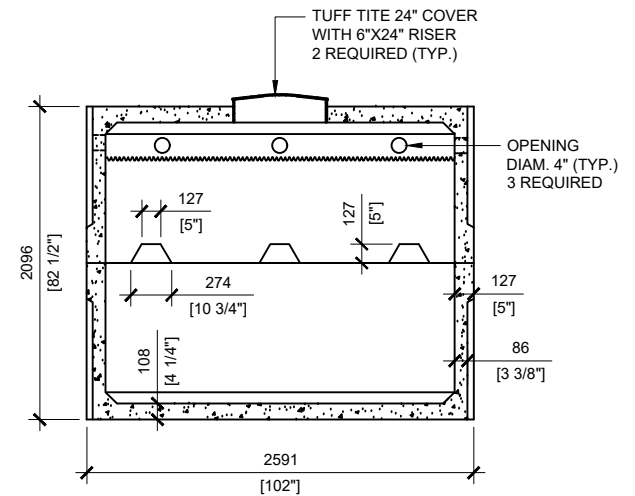

SECTION B
SCALE:1/50



MANUFACTURED:
BROOKLIN, ON
1-800-655-3430

CONCRETE: 35MPa at 28 days / 5000PSI
AIR ENTRAINMENT: 6-8%
MEETS CAN/CSA-B66-00
REINFORCEMENT: STEEL TO CSA CAN
A23.1 / A23.3 G30.18 Fy=400MPa

WEIGHT: 31,140lbs / 14,125kg
BOTTOM: 15,780lbs
TOP: 15,360lbs
CPA CERTIFIED

DRAWN BY:
S.RIMLAND
DATE:
JAN/2018

18000 LITRES
4000 IMPERIAL GALLON

SEPTIC TANK

WORKING CAPACITY: 18,470 LITRES TO INVERT OF OUTLET
TOTAL CAPACITY: 21,007 LITRES TO UNDERSIDE OF CHAMBER LID