

TOP VIEW  
SCALE: 1/50

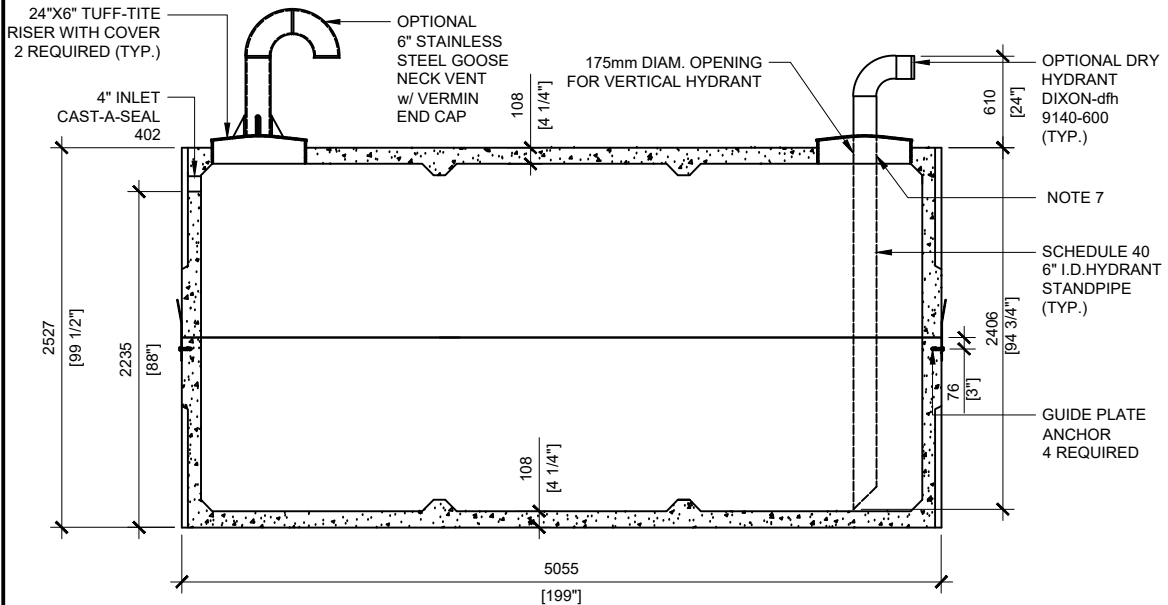

SECTION A  
SCALE: 1/50

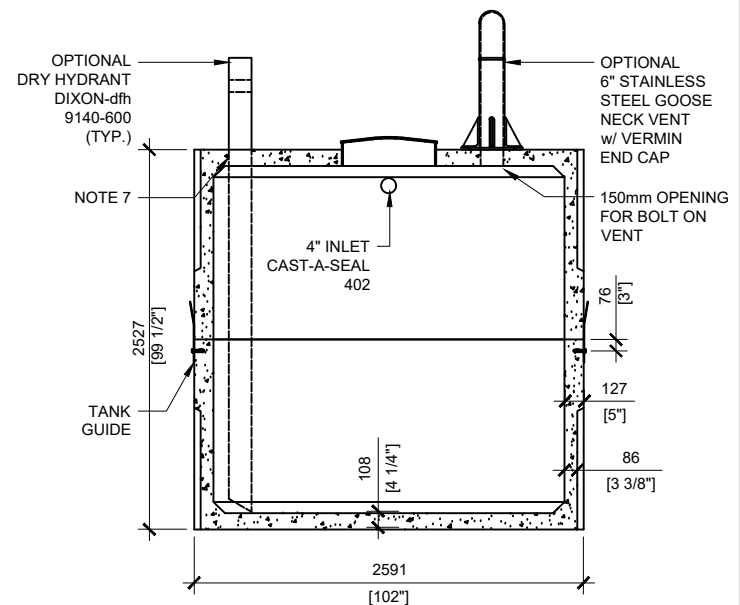

SECTION B  
SCALE: 1/50

**GENERAL NOTES:**

1. UNITS ARE SEALED WITH BUTYL TAPE AT THE JOINTS
2. DELIVERY IS MADE BY CRANE-EQUIPPED TRUCKS
3. EXCAVATION MUST BE READY, SAFE AND ACCESSIBLE FOR UNLOADING FROM THE REAR OF THE TRUCK.
4. MIN OVERHEAD CLEARANCE OF 18FT (5.5 METRES) IS REQUIRED
5. ALL UNITS MUST BE HANDLED WITH PROPER LIFTING EQUIPMENT
6. MAXIMUM BURIAL DEPTH = 1 METRE IN FIRM SOIL AWAY FROM ANY VEHICULAR TRAFFIC
7. SCHEDULE 80 FLANGE FOR DRY HYDRANT TO BE FITTED ON SITE

**\*SINGLE FIRE WATER TANK\***



MANUFACTURED:  
BROOKLIN, ON  
1-800-655-3430

CONCRETE: 35MPa/ 5000PSI  
AIR ENTRAINMENT: 5-8%  
REINFORCEMENT: STEEL TO CSA CAN  
A23.1 /A23.3 G30.18 Fy=400MPa

WEIGHT: 34,870lbs / 15,850kg  
BOTTOM: 17,690lbs / 8,041kg  
TOP: 17,180lbs / 7,809kg  
CPA CERTIFIED  
MEETS CAN/CSA-B66  
"AGINP"

DRAWN BY:  
N.CHAN

DATE:  
MAR/2021

**22000 LITRES**

WORKING CAPACITY: 23,820L TO INVERT OF INLET  
TOTAL CAPACITY: 25,852L TO UNDERSIDE OF CHAMBER LID