

TOP VIEW
SCALE: 1/50

GENERAL NOTES:

1. UNITS ARE SEALED WITH BUTYL TAPE AT THE JOINTS
2. DELIVERY IS MADE BY CRANE-EQUIPPED TRUCKS
3. EXCAVATION MUST BE READY, SAFE AND ACCESSIBLE FOR UNLOADING FROM THE REAR OF THE TRUCK.
4. MIN OVERHEAD CLEARANCE OF 18FT (5.5 METRES) IS REQUIRED
5. ALL UNITS MUST BE HANDLED WITH PROPER LIFTING EQUIPMENT
6. MAXIMUM BURIAL DEPTH = 1 METRE IN FIRM SOIL AWAY FROM ANY VEHICULAR TRAFFIC

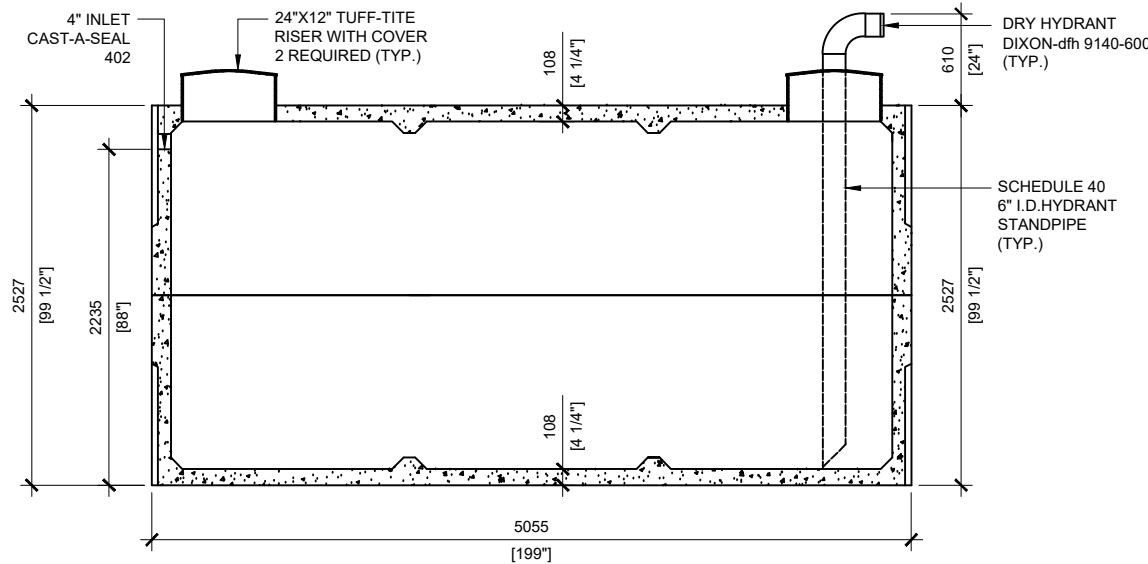

SECTION A
SCALE: 1/50

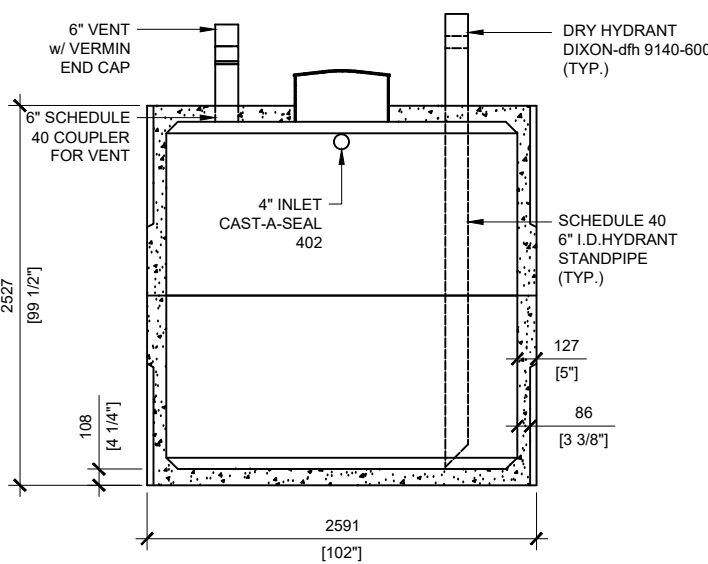

SECTION B
SCALE: 1/50

SINGLE FIRE WATER TANK



MANUFACTURED:
BROOKLIN, ON
1-800-655-3430

CONCRETE: 35MPa/ 5000PSI
AIR ENTRAINMENT: 5-8%
REINFORCEMENT: STEEL TO CSA CAN
A23.1 /A23.3 G30.18 Fy=400MPa

WEIGHT: 34,870lbs / 15,850kg
BOTTOM: 17,690lbs / 8,041kg
TOP: 17,180lbs / 7,809kg
CPA CERTIFIED
MEETS CAN/CSA-B66
"AGINP"

DRAWN BY:
N.CHAN
DATE:
FEB/2020

22750 LITRES
5000 IMPERIAL GALLON

WORKING CAPACITY: 23,820L TO INVERT OF INLET
TOTAL CAPACITY: 25,852L TO UNDERSIDE OF CHAMBER LID