

**GENERAL NOTES:**

1. UNITS ARE SEALED WITH BUTYL TAPE AT THE JOINTS
2. DELIVERY IS MADE BY CRANE-EQUIPPED TRUCKS
3. EXCAVATION MUST BE READY, SAFE AND ACCESSIBLE FOR UNLOADING FROM THE REAR OF THE TRUCK.
4. MIN OVERHEAD CLEARANCE OF 18FT (5.5 METRES) IS REQUIRED
5. ALL UNITS MUST BE HANDLED WITH PROPER LIFTING EQUIPMENT
6. MAXIMUM BURIAL DEPTH = 1 METRE IN FIRM SOIL AWAY FROM ANY VEHICULAR TRAFFIC

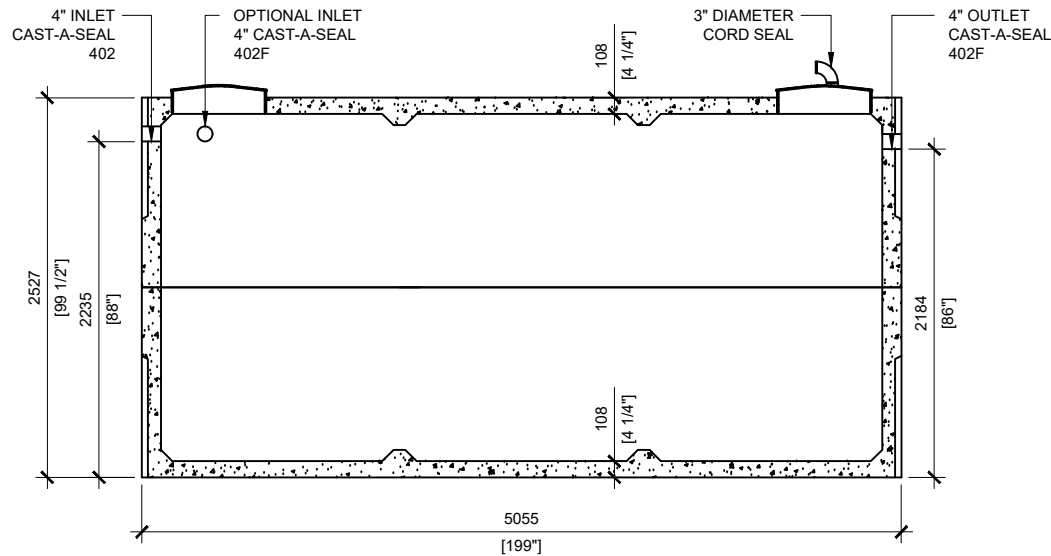

SECTION A  
SCALE: 1/50

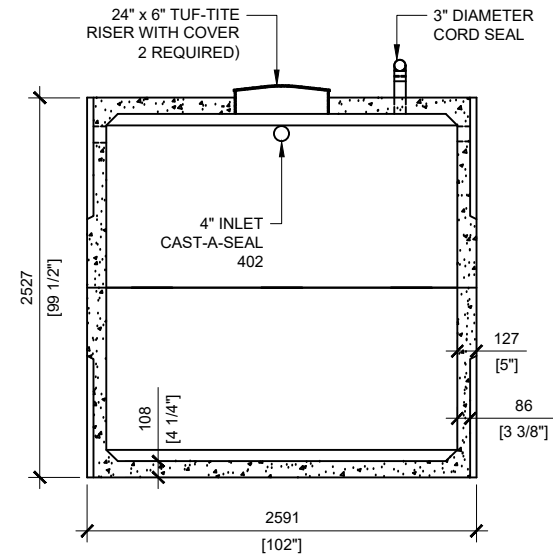

SECTION B  
SCALE: 1/50



MANUFACTURED:  
BROOKLIN, ON  
1-800-655-3430

CONCRETE: 35MPa at 28 days/5000PSI  
AIR ENTRAINMENT: 5-8%  
REINFORCEMENT: STEEL TO CSA CAN  
A23.1 /A23.3 G30.18 Fy=400MPa

WEIGHT: 34,870lbs / 15,820kg  
BOTTOM: 17,690lbs / 8,041kg  
TOP: 17,180lbs / 7,809kg  
CPA CERTIFIED  
MEETS CAN/CSA-B66  
"AGINP"

DRAWN BY:  
N.CHAN

DATE:  
JAN/2020

**22750 LITRES** SINGLE  
5000 IMPERIAL GALLON CHAMBER

WORKING CAPACITY: 23,820L TO INVERT OF INLET  
TOTAL CAPACITY: 25,852L TO UNDERSIDE OF CHAMBER LID