

GENERAL NOTES:

1. UNITS ARE SEALED WITH BUTYL TAPE AT THE JOINTS
2. DELIVERY IS MADE BY CRANE-EQUIPPED TRUCKS
3. EXCAVATION MUST BE READY, SAFE AND ACCESSIBLE FOR UNLOADING FROM THE REAR OF THE TRUCK.
4. MIN OVERHEAD CLEARANCE OF 18FT IS REQUIRED
5. ALL UNITS MUST BE HANDLED WITH PROPER LIFTING EQUIPMENT (I.E. SPREADER BAR)
6. MAXIMUM BURIAL DEPTH = 1 METRE IN FIRM SOIL AWAY FROM ANY VEHICULAR TRAFFIC

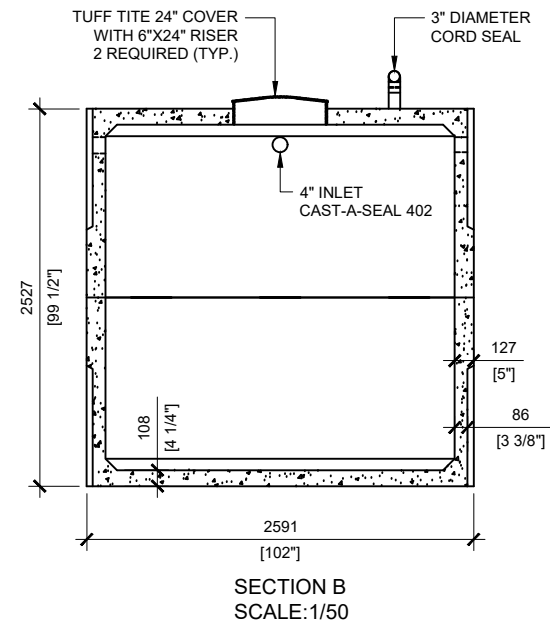
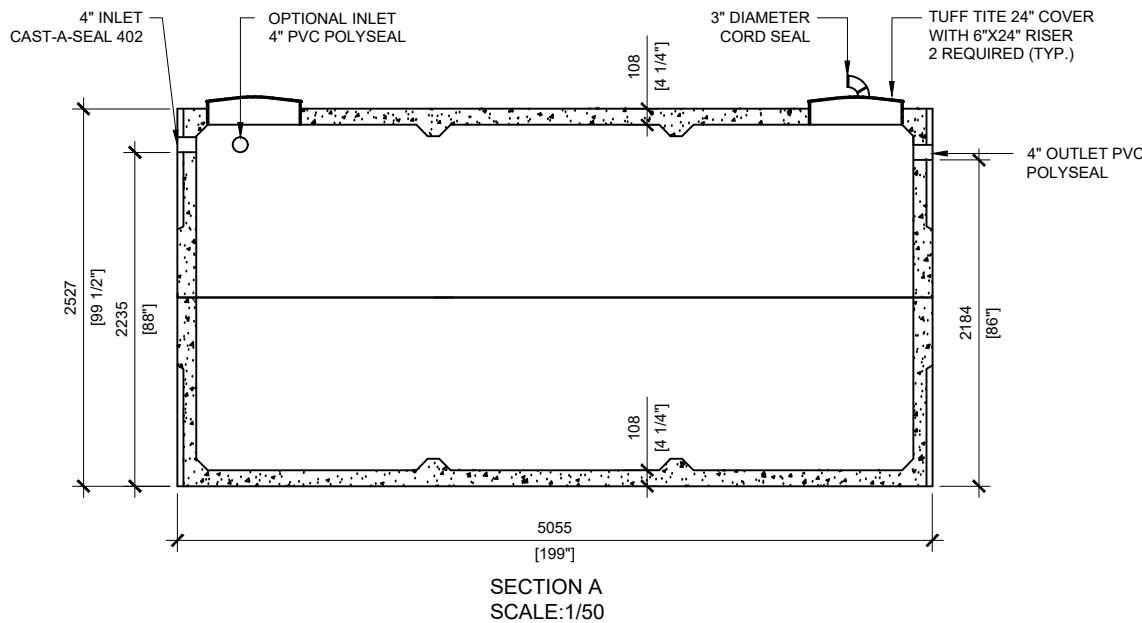

MANUFACTURED:
BROOKLIN, ON
1-800-655-3430

CONCRETE: 35MPa at 28 days/5000PSI
AIR ENTRAINMENT: 6-8%
MEETS CAN/CSA-B66-00
REINFORCEMENT: STEEL TO CSA CAN
A23.1 /A23.3 G30.18 Fy=400MPa

WEIGHT: 34,870lbs / 15,820kg
CPA CERTIFIED

DRAWN BY:
S.RIMLAND

DATE:
JAN/2018

22750 LITRES SINGLE
5000 IMPERIAL GALLON CHAMBER

5,000 IMPERIAL GALLON / 22,750 LITRES SINGLE CHAMBER