

- GENERAL NOTES:**
1. UNITS ARE SEALED WITH BUTYL TAPE AT THE JOINTS
 2. DELIVERY IS MADE BY CRANE-EQUIPPED TRUCKS
 3. EXCAVATION MUST BE READY, SAFE AND ACCESSIBLE FOR UNLOADING FROM THE REAR OF THE TRUCK.
 4. MIN OVERHEAD CLEARANCE OF 18FT (5.5 METRES) IS REQUIRED
 5. ALL UNITS MUST BE HANDLED WITH PROPER LIFTING EQUIPMENT
 6. MAXIMUM BURIAL DEPTH = 1 METRE IN FIRM SOIL AWAY FROM ANY VEHICULAR TRAFFIC
 7. TUF-TITE SAFETY LID INSTALLED IN OPENING AS PER CSA-B66-21

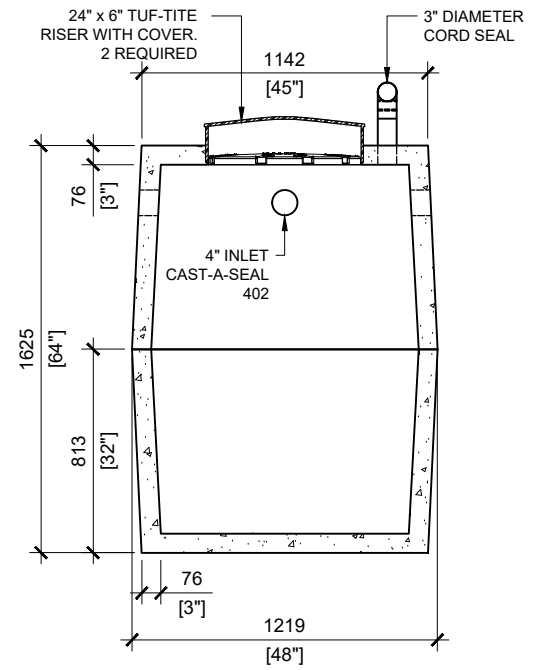
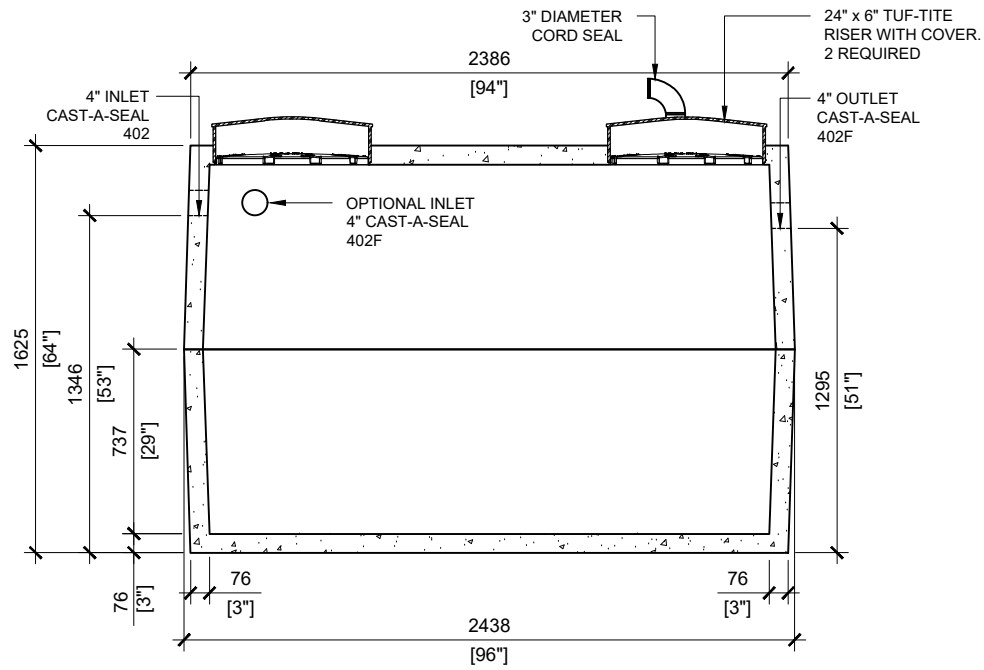

MANUFACTURED:
BROOKLIN, ON
1-800-655-3430

CONCRETE: 35MPa at 28 days/5000PSI
AIR ENTRAINMENT: 5-8%
REINFORCEMENT: STEEL TO CSA CAN
A23.1 /A23.3 G30.18 Fy=400MPa

UNIT WEIGHT: 5,720lbs / 2,594kg
CPA CERTIFIED
MEETS CAN/CSA-B66
"AGINP"

DRAWN BY:
JAY PATEL
DATE:
APRIL/2022

2900 LITRES

**PUMP
TANK**

WORKING CAPACITY: 2,970L TO INVERT OF INLET
TOTAL CAPACITY: 3,423L TO UNDERSIDE OF CHAMBER LID