

**GENERAL NOTES:**

1. UNITS ARE SEALED WITH BUTYL TAPE AT THE JOINTS
2. DELIVERY IS MADE BY CRANE-EQUIPPED TRUCKS
3. EXCAVATION MUST BE READY, SAFE AND ACCESSIBLE FOR UNLOADING FROM THE REAR OF THE TRUCK.
4. MIN OVERHEAD CLEARANCE OF 18FT IS REQUIRED
5. ALL UNITS MUST BE HANDLED WITH PROPER LIFTING EQUIPMENT (I.E. SPREADER BAR)
6. MAXIMUM BURIAL DEPTH = 1 METRE IN FIRM SOIL AWAY FROM ANY VEHICULAR TRAFFIC

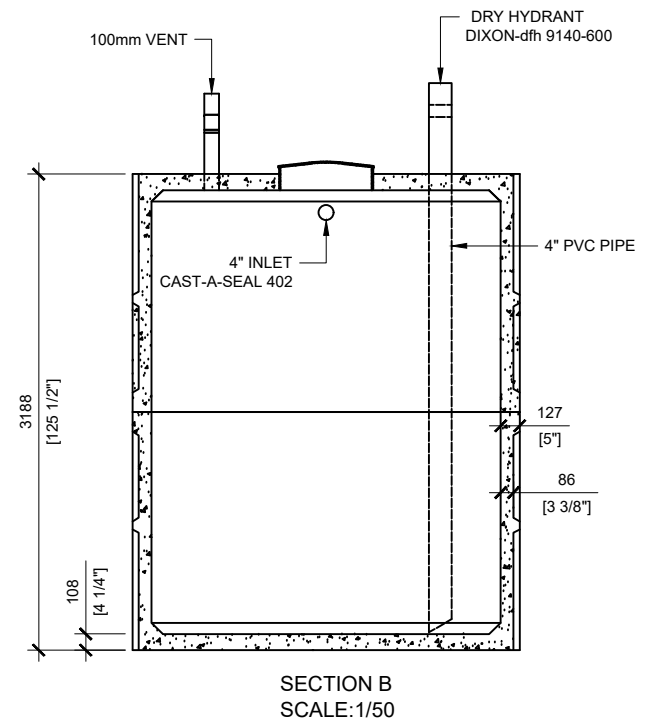

**\*SINGLE FIRE WATER TANK\***

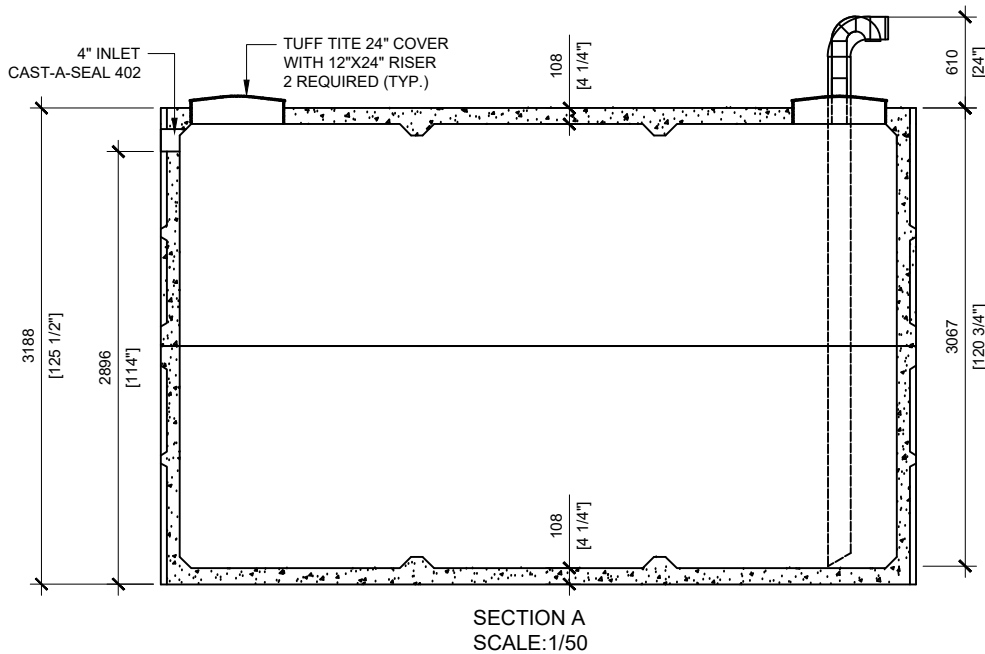

MANUFACTURED:  
BROOKLIN, ON  
1-800-655-3430

CONCRETE: 35MPa/5000PSI  
AIR ENTRAINMENT: 6-8%  
MEETS CAN/CSA-B66-00  
REINFORCEMENT: STEEL TO CSA CAN  
A23.1 /A23.3 G30.18 Fy=400MPa

WEIGHT: 40,905lbs / 18,555kg  
CPA CERTIFIED

DRAWN BY:  
S.RIMLAND

DATE:  
JAN/2018

**30000 LITRES**  
6600 IMPERIAL GALLON

TOTAL CAPACITY: 33,918 LITRES TO UNDERSIDE OF CHAMBER LID