

GENERAL NOTES:

1. UNITS ARE SEALED WITH BUTYL TAPE AT THE JOINTS
2. DELIVERY IS MADE BY CRANE-EQUIPPED TRUCKS
3. EXCAVATION MUST BE READY, SAFE AND ACCESSIBLE FOR UNLOADING FROM THE REAR OF THE TRUCK.
4. MIN OVERHEAD CLEARANCE OF 18FT IS REQUIRED
5. ALL UNITS MUST BE HANDLED WITH PROPER LIFTING EQUIPMENT
6. MAXIMUM BURIAL DEPTH = 1 METRE IN FIRM SOIL AWAY FROM ANY VEHICULAR TRAFFIC

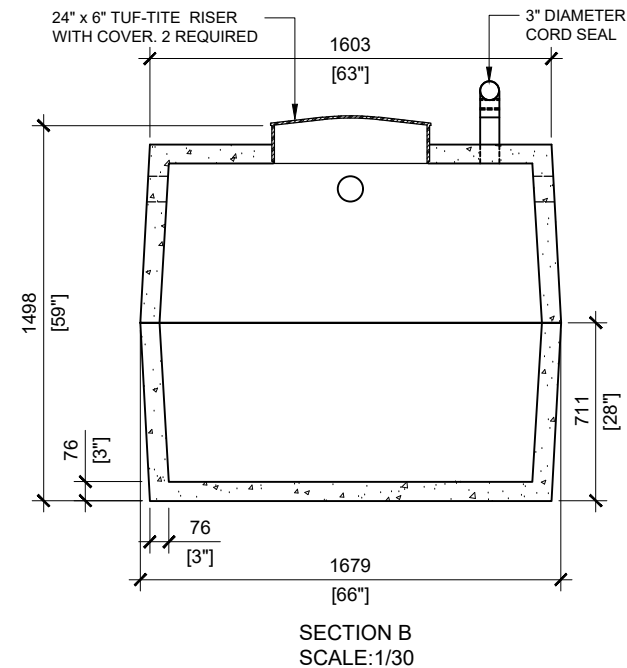
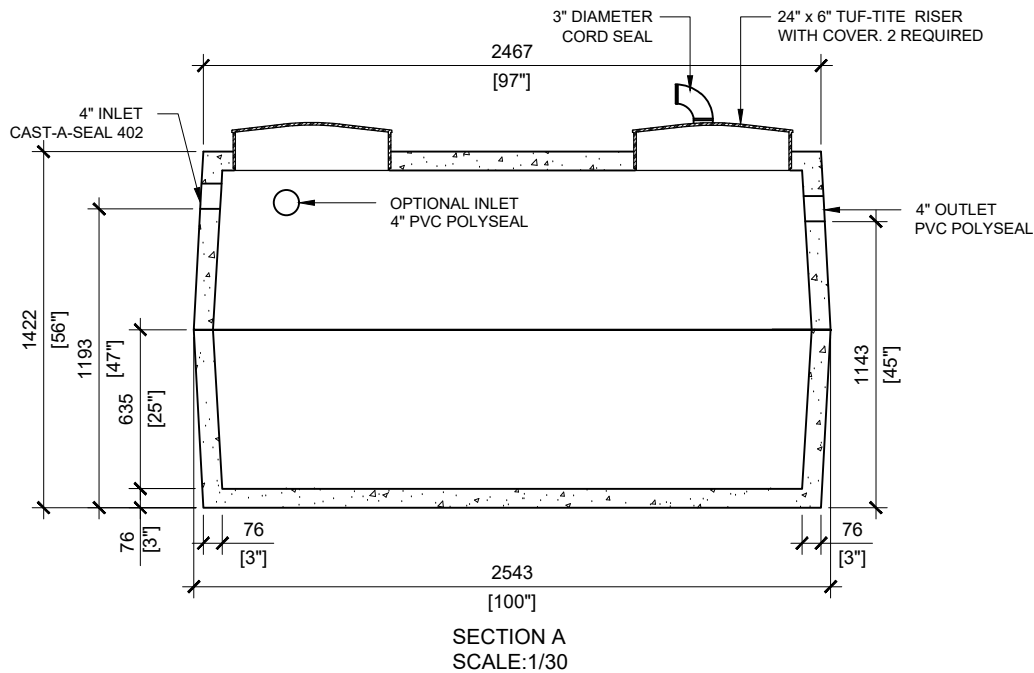

MANUFACTURED:
BROOKLIN, ON
1-800-655-3430

CONCRETE: 35MPa at 28 days/5000PSI
AIR ENTRAINMENT: 6-8%
REINFORCEMENT: STEEL TO CSA CAN
A23.1 /A23.3 G30.18 Fy=400MPa

UNIT WEIGHT: 6,940lbs / 3,147kg
CPA CERTIFIED
MEETS CAN/CSA-B66

DRAWN BY:
S.RIMLAND

DATE:
JAN/2019

3600 LITRES LOW HEIGHT
800 IMPERIAL GALLON PUMP TANK

WORKING CAPACITY: 3,931L TO INVERT OF INLET

TOTAL CAPACITY: 4,450L TO UNDERSIDE OF CHAMBER LID