

**GENERAL NOTES:**

1. UNITS ARE SEALED WITH BUTYL TAPE AT THE JOINTS
2. DELIVERY IS MADE BY CRANE-EQUIPPED TRUCKS
3. EXCAVATION MUST BE READY, SAFE AND ACCESSIBLE FOR UNLOADING FROM THE REAR OF THE TRUCK.
4. MIN OVERHEAD CLEARANCE OF 18FT IS REQUIRED
5. ALL UNITS MUST BE HANDLED WITH PROPER LIFTING EQUIPMENT (I.E. SPREADER BAR)
6. MAXIMUM BURIAL DEPTH = 1 METRE IN FIRM SOIL AWAY FROM ANY VEHICULAR TRAFFIC

\*WILL BE CONVERTING TO A 2" CAST-A-SEAL OUTLET FOR 2018\*

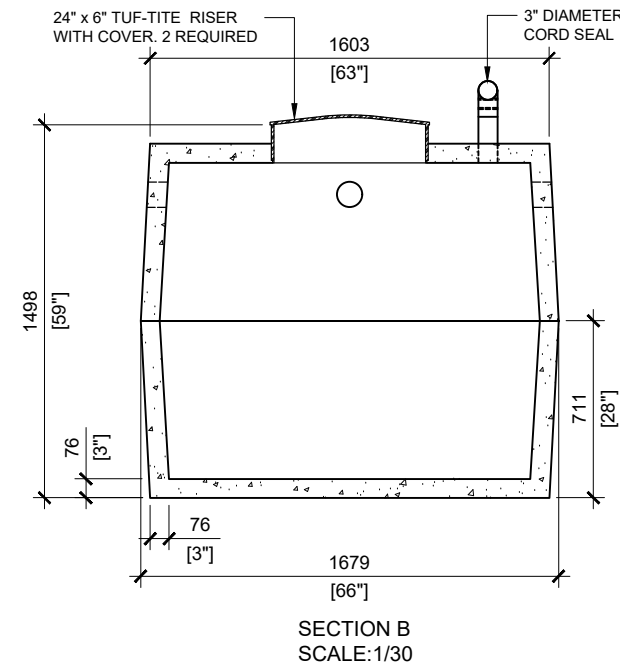
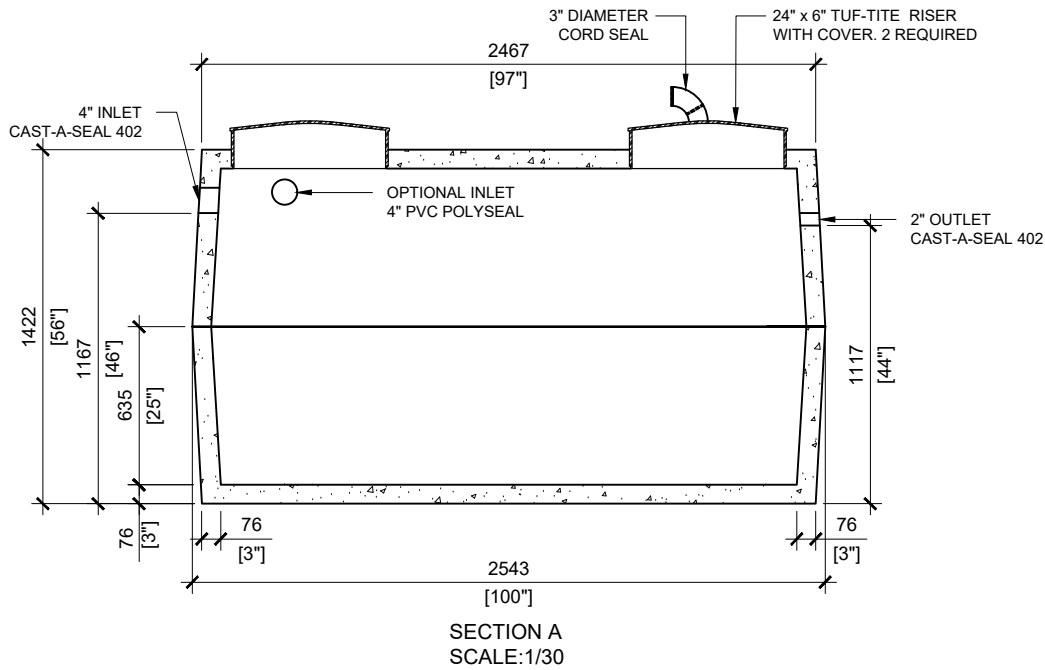

MANUFACTURED:  
BROOKLIN, ON  
1-800-655-3430

CONCRETE: 35MPa at 28 days/5000PSI  
AIR ENTRAINMENT: 6-8%  
REINFORCEMENT: STEEL TO CSA CAN  
A23.1 /A23.3 G30.18 Fy=400MPa

UNIT WEIGHT: 6,940lbs / 3,147kg  
CPA CERTIFIED  
MEETS CSA-B66

DRAWN BY:  
S.RIMLAND  
DATE:  
JAN/2018

**3600 LITRES** LOW HEIGHT  
800 IMPERIAL GALLON PUMP TANK

800 IMPERIAL GALLON / 3,600 LITRES