

**GENERAL NOTES:**

1. UNITS ARE SEALED WITH BUTYL TAPE AT THE JOINTS
2. DELIVERY IS MADE BY CRANE-EQUIPPED TRUCKS
3. EXCAVATION MUST BE READY, SAFE AND ACCESSIBLE FOR UNLOADING FROM THE REAR OF THE TRUCK.
4. MIN OVERHEAD CLEARANCE OF 18FT IS REQUIRED
5. ALL UNITS MUST BE HANDLED WITH PROPER LIFTING EQUIPMENT (I.E. SPREADER BAR)
6. MAXIMUM BURIAL DEPTH = 1 METRE IN FIRM SOIL AWAY FROM ANY VEHICULAR TRAFFIC

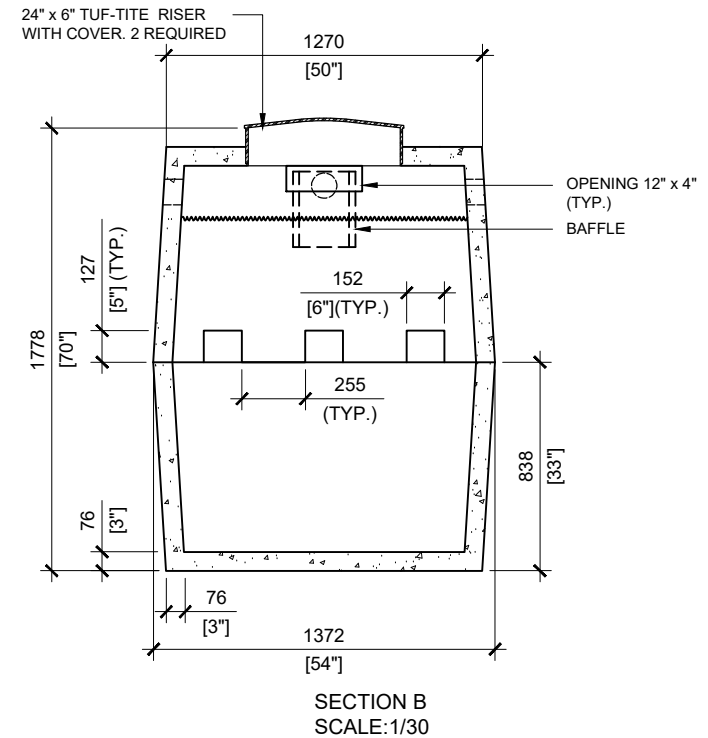
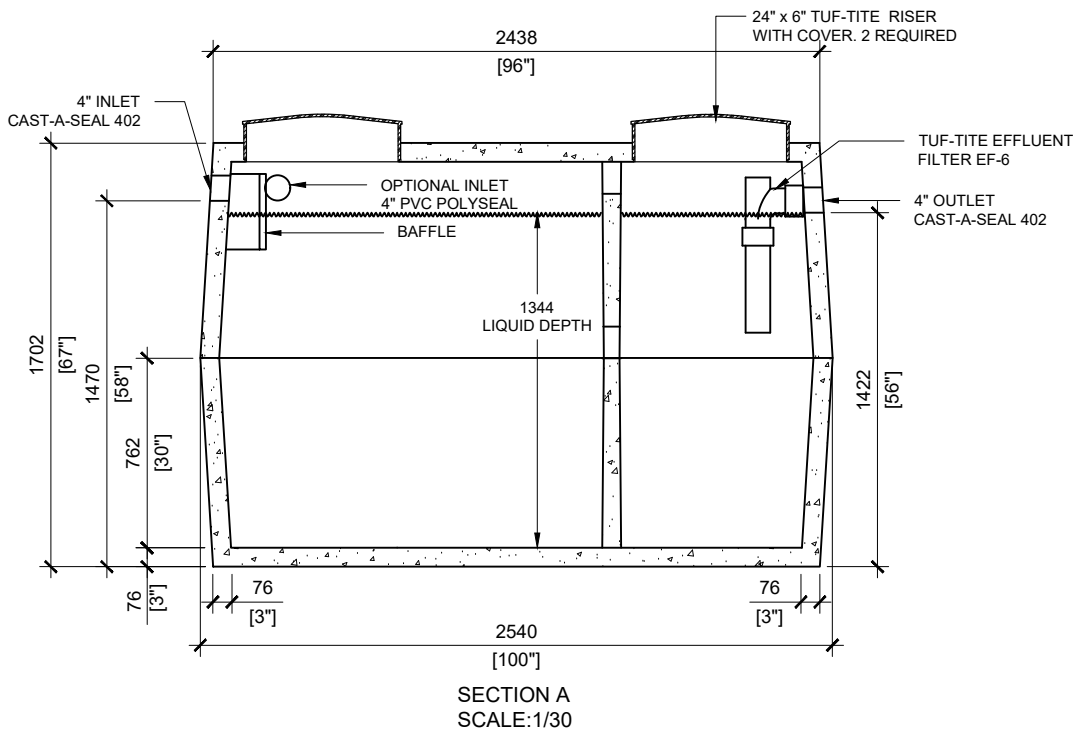

MANUFACTURED:  
BROOKLIN, ON  
1-800-655-3430

CONCRETE: 35MPa at 28 days / 5000PSI  
AIR ENTRAINMENT: 6-8%  
REINFORCEMENT: STEEL TO CSA CAN  
A23.1 /A23.3 G30.18 Fy=400MPa

UNIT WEIGHT: 6,490lbs / 2,943kg  
CPA CERTIFIED  
MEETS CSA-B66

DRAWN BY:  
S.RIMLAND

DATE:  
JAN / 2018

**3600 LITRES SEPTIC TANK**  
800 IMPERIAL GALLON

WORKING CAPACITY: 3,723 LITRES TO INVERT OF OUTLET  
TOTAL CAPACITY: 4,259 LITRES TO UNDERSIDE OF CHAMBER LID