

TOP VIEW  
SCALE:1/16

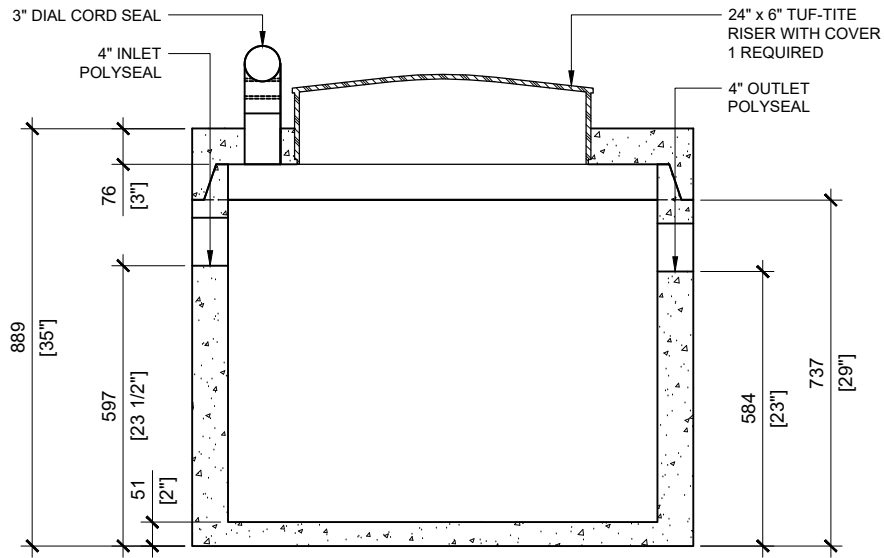

SECTION A  
SCALE:1/16

**GENERAL NOTES:**

1. BUTYL TAPE PROVIDED FOR CONTRACTOR TO SEAL CONCRETE LID
2. DELIVERY IS MADE BY CRANE-EQUIPPED TRUCKS
3. EXCAVATION MUST BE READY, SAFE AND ACCESSIBLE FOR UNLOADING FROM THE REAR OF THE TRUCK.
4. MIN OVERHEAD CLEARANCE OF 18FT (5.5 METRES) IS REQUIRED
5. ALL UNITS MUST BE HANDLED WITH PROPER LIFTING EQUIPMENT
6. MAXIMUM BURIAL DEPTH = 1 METRE IN FIRM SOIL AWAY FROM ANY VEHICULAR TRAFFIC

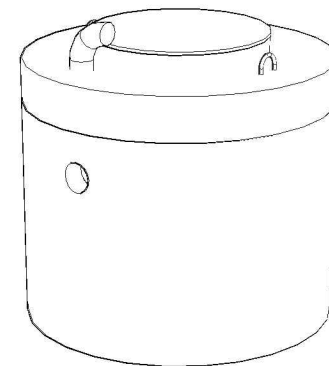

MANUFACTURED:  
BROOKLIN, ON  
1-800-655-3430

CONCRETE: 35MPa/5000PSI  
AIR ENTRAINMENT: 5-8%  
REINFORCEMENT: STEEL TO CSA CAN  
A23.1 /A23.3 G30.18 Fy=400MPa

WEIGHT:  
1,460lbs / 662kg  
CPA CERTIFIED  
MEETS CAN/CSA-B66  
"AGINP"

DRAWN BY:  
S.RIMLAND

DATE:  
JAN/2020

**364 LITRES**  
80 IMPERIAL GALLON

WORKING CAPACITY: 372L TO INVERT OF INLET

TOTAL CAPACITY: 450L TO UNDERSIDE OF CHAMBER LID

**PUMP  
TANK**