

**GENERAL NOTES:**

1. UNITS ARE SEALED WITH BUTYL TAPE AT THE JOINTS
2. DELIVERY IS MADE BY CRANE-EQUIPPED TRUCKS
3. EXCAVATION MUST BE READY, SAFE AND ACCESSIBLE FOR UNLOADING FROM THE REAR OF THE TRUCK.
4. MIN OVERHEAD CLEARANCE OF 18FT (5.5 METRES) IS REQUIRED
5. ALL UNITS MUST BE HANDLED WITH PROPER LIFTING EQUIPMENT
6. MAXIMUM BURIAL DEPTH = 1 METRE IN FIRM SOIL AWAY FROM ANY VEHICULAR TRAFFIC

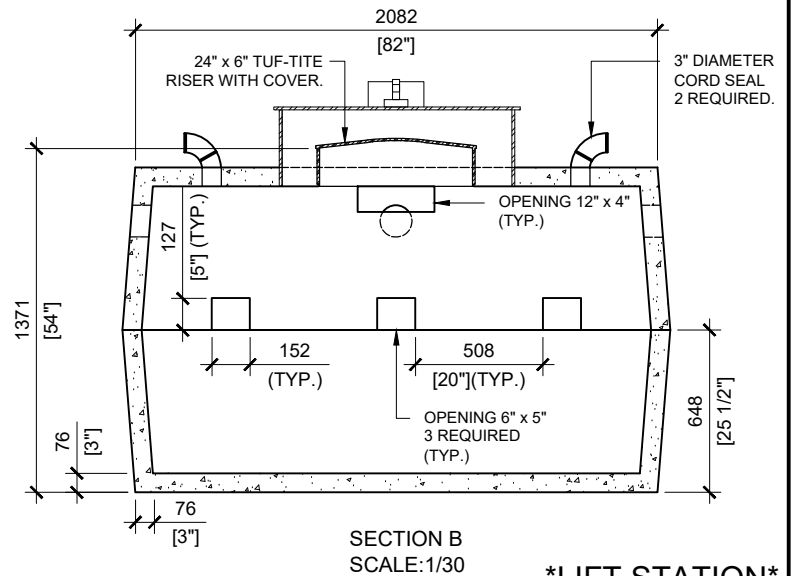

**\*LIFT STATION\***

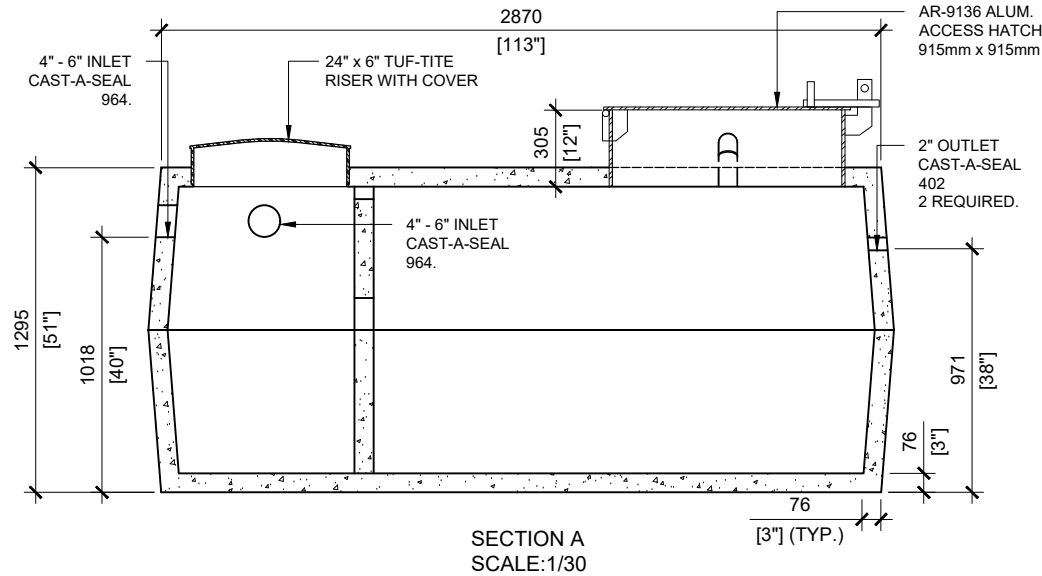

MANUFACTURED:  
BROOKLIN, ON  
1-800-655-3430

CONCRETE: 35MPa at 28 days / 5000PSI  
AIR ENTRAINMENT: 5-8%  
REINFORCEMENT: STEEL TO CSA CAN  
A23.1 /A23.3 G30.18 Fy=400MPa

UNIT WEIGHT: 11,620lbs / 5,270kg  
CPA CERTIFIED  
MEETS CAN/CSA-B66  
"AGINP"

DRAWN BY:  
N.CHAN

DATE:  
MAR/2021

**5000 LITRES** LOW HEIGHT  
SEPTIC TANK

5,000 LITRES