

TOP VIEW  
SCALE:1/30

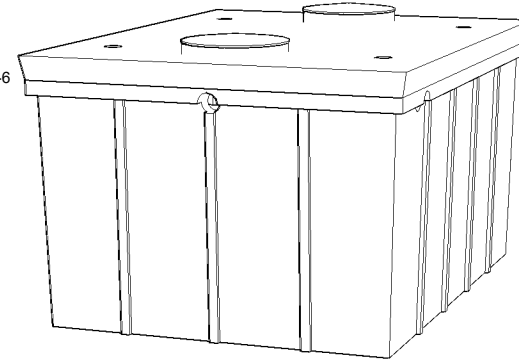

**GENERAL NOTES:**

1. UNITS ARE SEALED WITH BUTYL TAPE AT THE JOINTS
2. DELIVERY IS MADE BY CRANE-EQUIPPED TRUCKS
3. EXCAVATION MUST BE READY, SAFE AND ACCESSIBLE FOR UNLOADING FROM THE REAR OF THE TRUCK.
4. MIN OVERHEAD CLEARANCE OF 18FT (5.5 METRES) IS REQUIRED
5. ALL UNITS MUST BE HANDLED WITH PROPER LIFTING EQUIPMENT
6. MAXIMUM BURIAL DEPTH = 1 METRE IN FIRM SOIL AWAY FROM ANY VEHICULAR TRAFFIC
7. TUF-TITE SAFETY LIDS INSTALLED IN BOTH OPENINGS AS PER CSA-B66-21

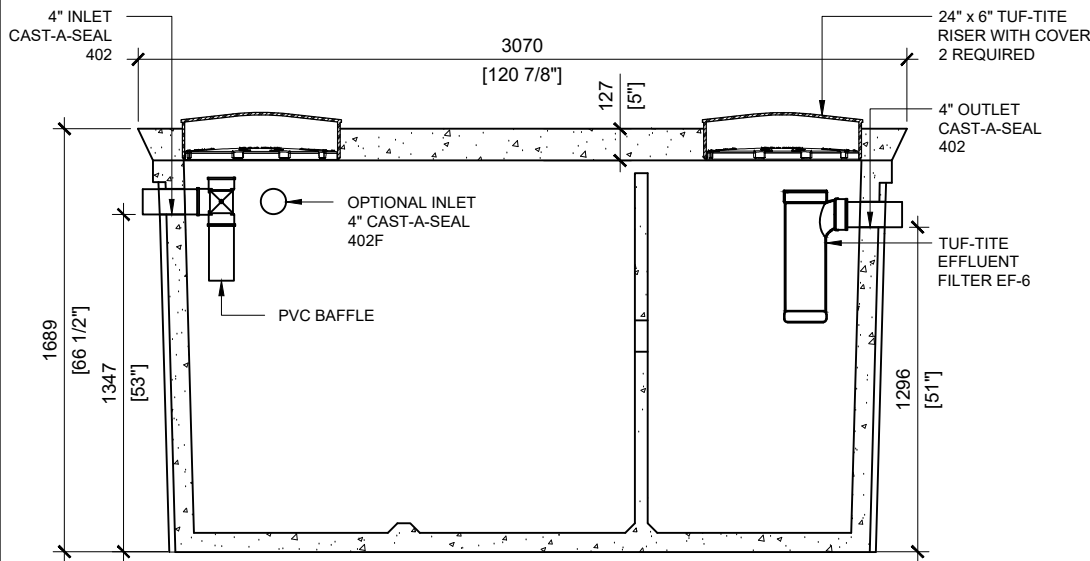

SECTION A  
SCALE:1/30

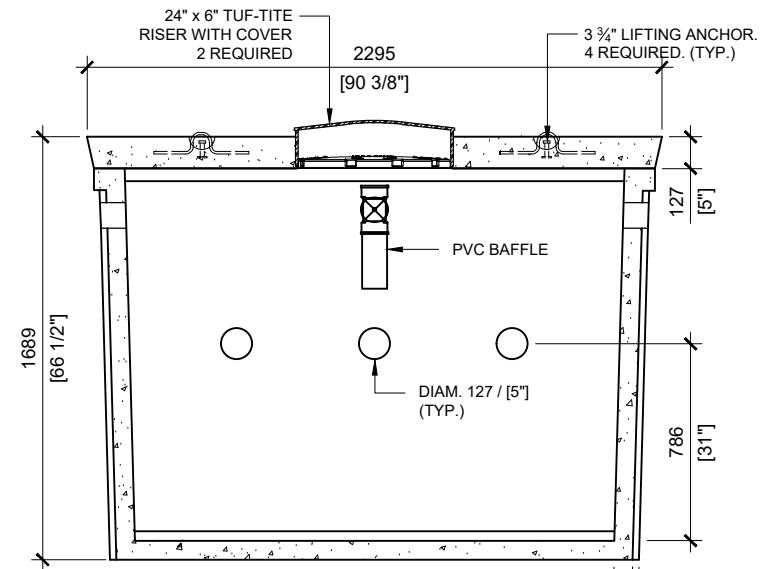

SECTION B  
SCALE:1/30



**MANUFACTURED:**  
LINDSAY, ON  
1-800-655-3430

**CONCRETE:** 35MPa at 28 days/5000PSI  
**AIR ENTRAINMENT:** 5-8%  
**REINFORCEMENT:** STEEL TO CSA CAN  
A23.1 /A23.3 G30.18 Fy=400MPa

**UNIT WEIGHT:** 15,216lbs / 6,902kg  
CPA CERTIFIED  
MEETS CAN/CSA-B66  
"AGINP"

**DRAWN BY:**  
PRASHAN

**DATE:**  
MAR/2024

**6000 LITRES SEPTIC TANK**

**WORKING CAPACITY:** 6,154L TO INVERT OF OUTLET  
**TOTAL CAPACITY:** 7,572L TO UNDERSIDE OF CHAMBER LID