

680 & 1365 LITRES TOP VIEW
SCALE: 1/20

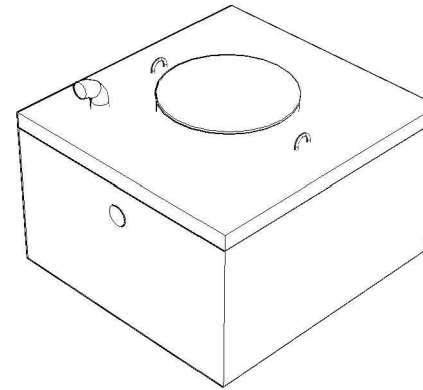

GENERAL NOTES:

1. UNITS ARE SEALED WITH BUTYL TAPE AT THE JOINTS
2. DELIVERY IS MADE BY CRANE-EQUIPPED TRUCKS
3. EXCAVATION MUST BE READY, SAFE AND ACCESSIBLE FOR UNLOADING FROM THE REAR OF THE TRUCK.
4. MIN OVERHEAD CLEARANCE OF 18FT IS REQUIRED
5. ALL UNITS MUST BE HANDLED WITH PROPER LIFTING EQUIPMENT
6. MAXIMUM BURIAL DEPTH = 1 METRE IN FIRM SOIL AWAY FROM ANY VEHICULAR TRAFFIC

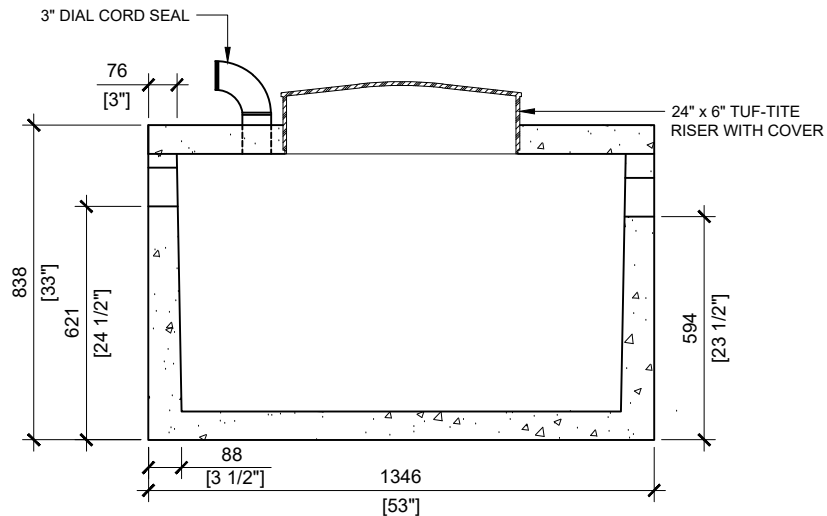

680 LITRES SECTION A
SCALE: 1/20

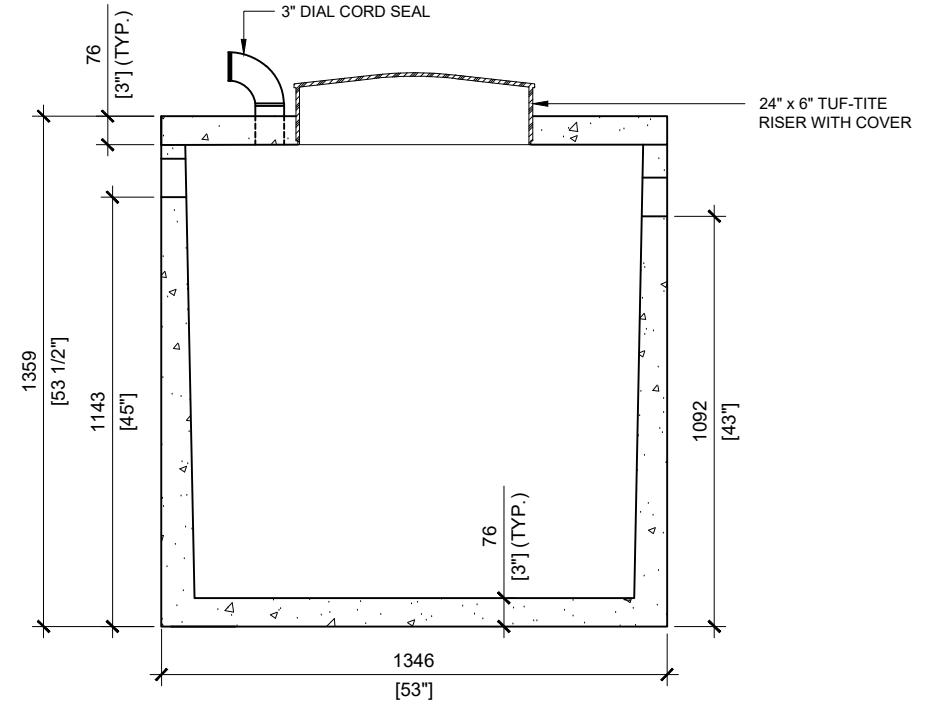

1365 LITRES SECTION A
SCALE: 1/20



MANUFACTURED:
BROOKLIN, ON
1-800-655-3430

CONCRETE: 35MPa/5000PSI
AIR ENTRAINMENT: 6-8%
REINFORCEMENT: STEEL TO CSA CAN
A23.1 /A23.3 G30.18 Fy=400MPa

WEIGHT:
680 LITRES- 2,520 lbs / 1,143kg
1365 LITRES- 3,560 lbs / 1,614kg
CPA CERTIFIED
MEETS CAN/CSA-B66

DRAWN BY:
S.RIMLAND
DATE:
JAN/2019

680 & 1365 LITRES PUMP TANK
150 & 300 IMPERIAL GALLON

WORKING CAPACITY: 719L & 1,435L TO INVERT OF INLET
TOTAL CAPACITY: 903L & 1,610L TO UNDERSIDE OF CHAMBER LID