

680 & 1365 LITRES TOP VIEW
SCALE: 1/20

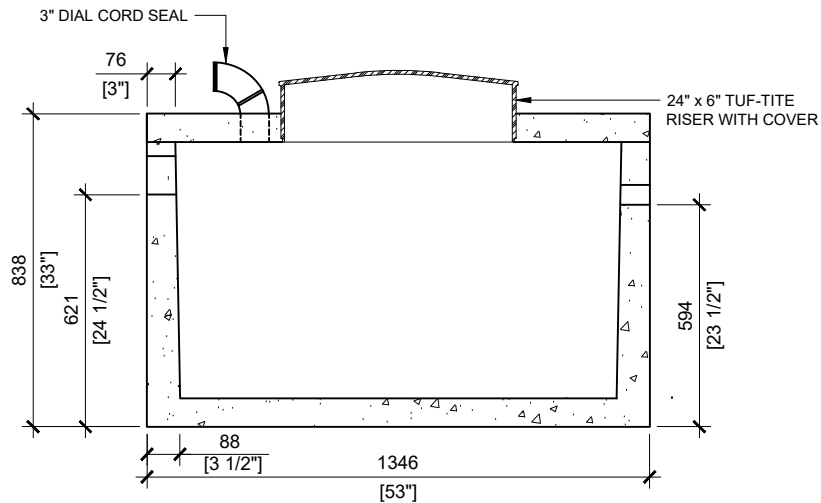

680 LITRES SECTION A
SCALE: 1/20

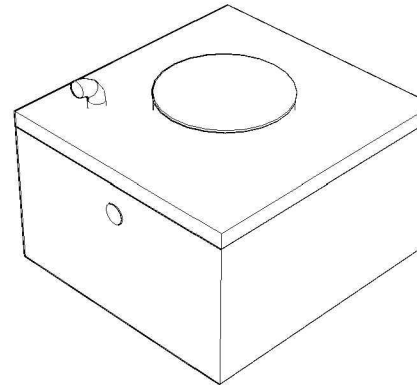

GENERAL NOTES:

1. UNITS ARE SEALED WITH BUTYL TAPE AT THE JOINTS
2. DELIVERY IS MADE BY CRANE-EQUIPPED TRUCKS
3. EXCAVATION MUST BE READY, SAFE AND ACCESSIBLE FOR UNLOADING FROM THE REAR OF THE TRUCK.
4. MIN OVERHEAD CLEARANCE OF 18FT IS REQUIRED
5. ALL UNITS MUST BE HANDLED WITH PROPER LIFTING EQUIPMENT (I.E. SPREADER BAR)
6. MAXIMUM BURIAL DEPTH = 1 METRE IN FIRM SOIL AWAY FROM ANY VEHICULAR TRAFFIC

WILL BE CONVERTING TO A 2" CAST-A-SEAL OUTLET FOR 2018

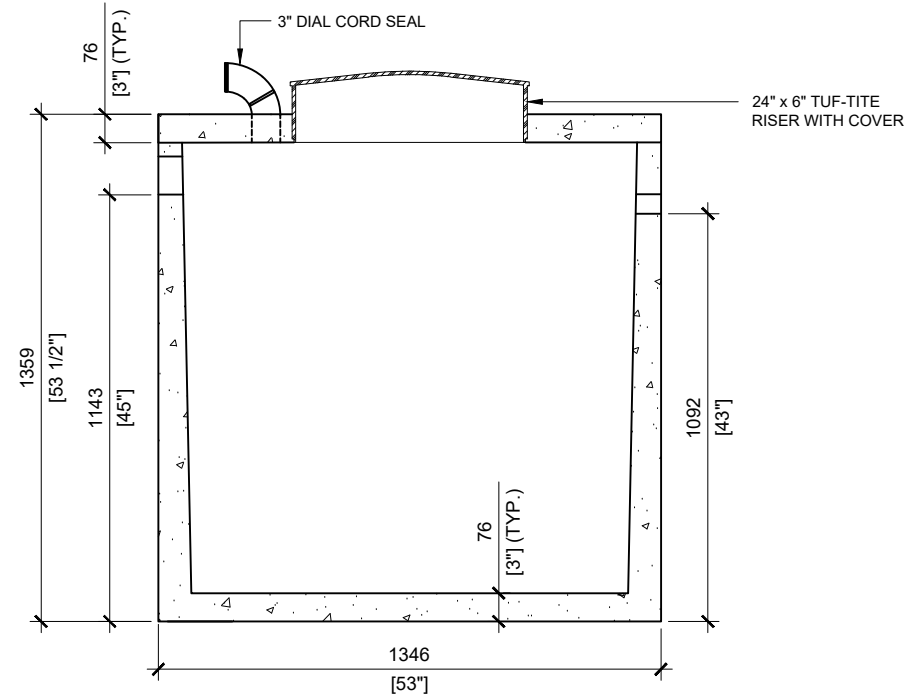

1365 LITRES SECTION A
SCALE: 1/20



MANUFACTURED:
BROOKLIN, ON
1-800-655-3430

CONCRETE: 35MPa at 28 days/5000PSI
AIR ENTRAINMENT: 6-8%
MEETS CAN/CSA-B66-00
REINFORCEMENT: STEEL TO CSA CAN
A23.1 /A23.3 G30.18 Fy=400MPa

CPA CERTIFIED WEIGHT:
680 LITRES- 2,520 lbs / 1,143kg
1365 LITRES- 3,560 lbs / 1,614kg

DRAWN BY:
S.RIMLAND
DATE:
JAN/2018

680 & 1365 LITRES PUMP TANK
150 & 300 IMPERIAL GALLON

150 & 300 IMPERIAL GALLON / 680 & 1365 LITRES