

TOP VIEW
SCALE: 1/40

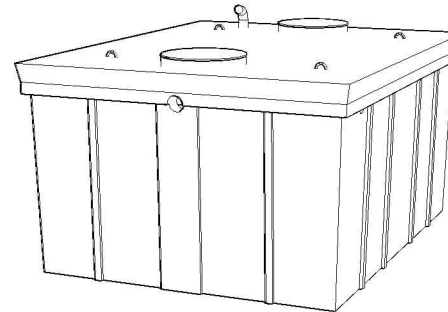

GENERAL NOTES:

1. UNITS ARE SEALED WITH BUTYL TAPE AT THE JOINTS
2. DELIVERY IS MADE BY CRANE-EQUIPPED TRUCKS
3. EXCAVATION MUST BE READY, SAFE AND ACCESSIBLE FOR UNLOADING FROM THE REAR OF THE TRUCK.
4. MIN OVERHEAD CLEARANCE OF 18FT (5.5 METRES) IS REQUIRED
5. ALL UNITS MUST BE HANDLED WITH PROPER LIFTING EQUIPMENT
6. MAXIMUM BURIAL DEPTH = 1 METRE IN FIRM SOIL AWAY FROM ANY VEHICULAR TRAFFIC

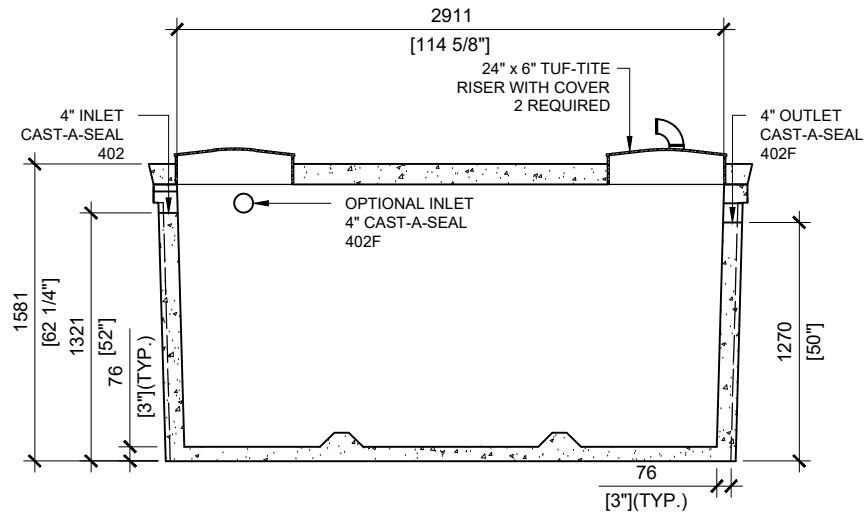

SECTION A
SCALE: 1/40

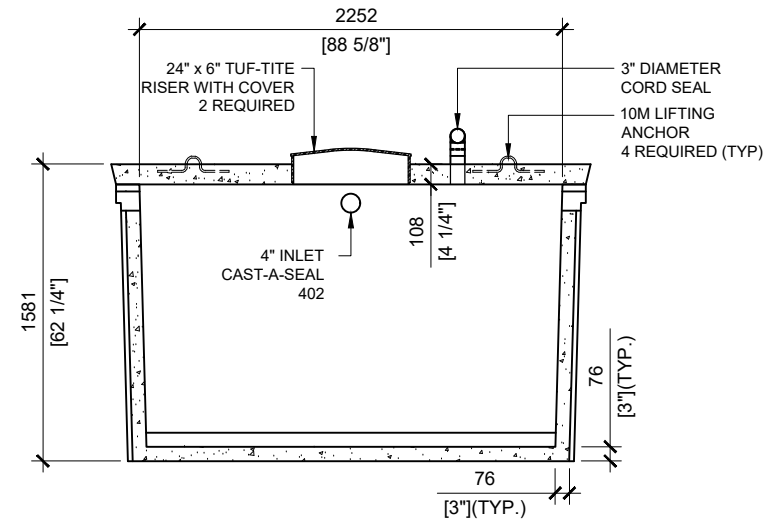

SECTION B
SCALE: 1/40



MANUFACTURED:
BROOKLIN, ON
1-800-655-3430

CONCRETE: 35MPa at 28 days/5000PSI
AIR ENTRAINMENT: 5-8%
REINFORCEMENT: STEEL TO CSA CAN
A23.1 /A23.3 G30.18 Fy=400MPa

UNIT WEIGHT: 14,460lbs / 6,560kg
CPA CERTIFIED
MEETS CAN/CSA-B66
"AGINP"

DRAWN BY:
S.RIMLAND

DATE:
JAN/2020

7000 LITRES
1550 IMPERIAL GALLON

WORKING CAPACITY: 7,899L TO INVERT OF INLET

TOTAL CAPACITY: 8,892L TO UNDERSIDE OF CHAMBER LID

**PUMP
TANK**