

**GENERAL NOTES:**

1. UNITS ARE SEALED WITH BUTYL TAPE AT THE JOINTS
2. DELIVERY IS MADE BY CRANE-EQUIPPED TRUCKS
3. EXCAVATION MUST BE READY, SAFE AND ACCESSIBLE FOR UNLOADING FROM THE REAR OF THE TRUCK.
4. MIN OVERHEAD CLEARANCE OF 18FT IS REQUIRED
5. ALL UNITS MUST BE HANDLED WITH PROPER LIFTING EQUIPMENT
6. MAXIMUM BURIAL DEPTH = 1 METRE IN FIRM SOIL AWAY FROM ANY VEHICULAR TRAFFIC

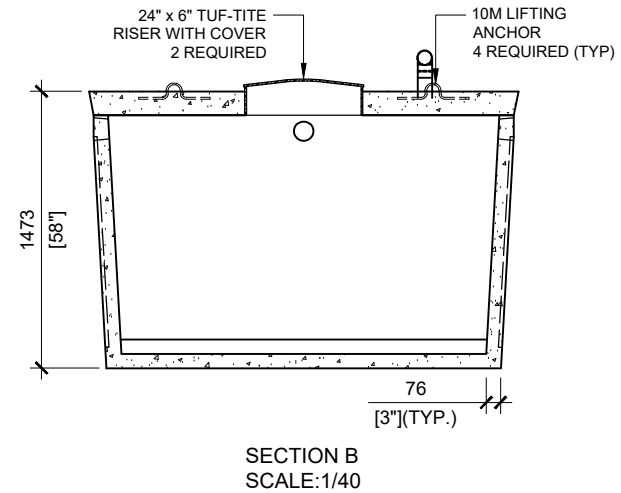
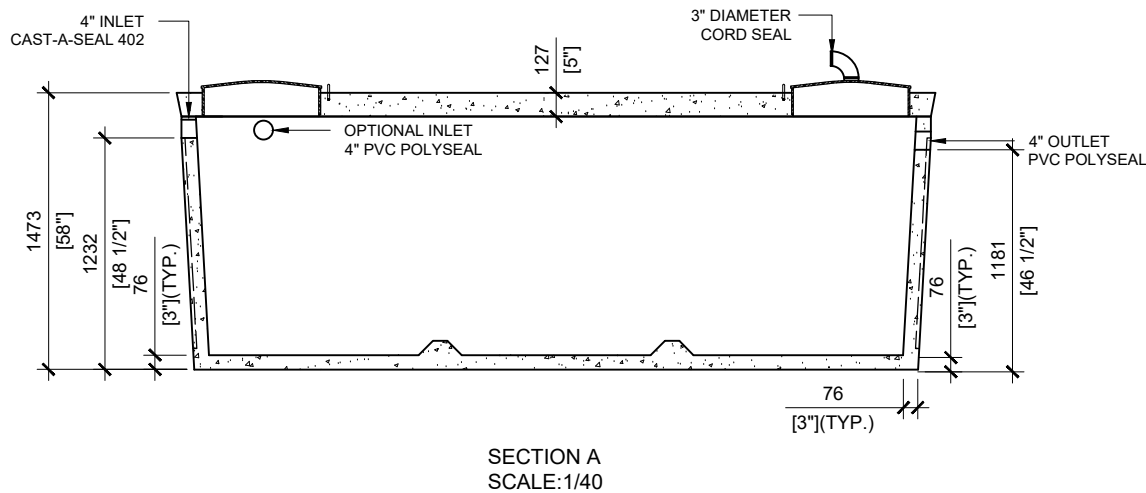

**MANUFACTURED:**  
BROOKLIN, ON  
1-800-655-3430

**CONCRETE:** 35MPa/5000PSI  
**AIR ENTRAINMENT:** 6-8%  
**REINFORCEMENT:** STEEL TO CSA CAN  
A23.1 / A23.3 G30.18 Fy=400MPa

**WEIGHT:** 17,250lbs / 7,825kg  
CPA CERTIFIED  
MEETS CAN/CSA-B66

**DRAWN BY:**  
S.RIMLAND

**DATE:**  
JAN/2019

**7500 LITRES LOW HEIGHT PUMP TANK**  
1650 IMPERIAL GALLON

**WORKING CAPACITY:** 8,846L TO INVERT OF INLET

**TOTAL CAPACITY:** 9,624L TO UNDERSIDE OF CHAMBER LID