

TOP VIEW
SCALE: 1/16

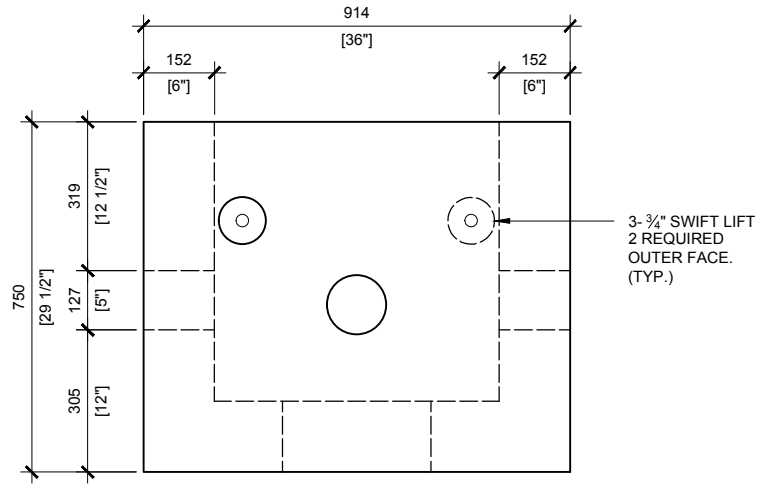

RIGHT VIEW
SCALE: 1/16

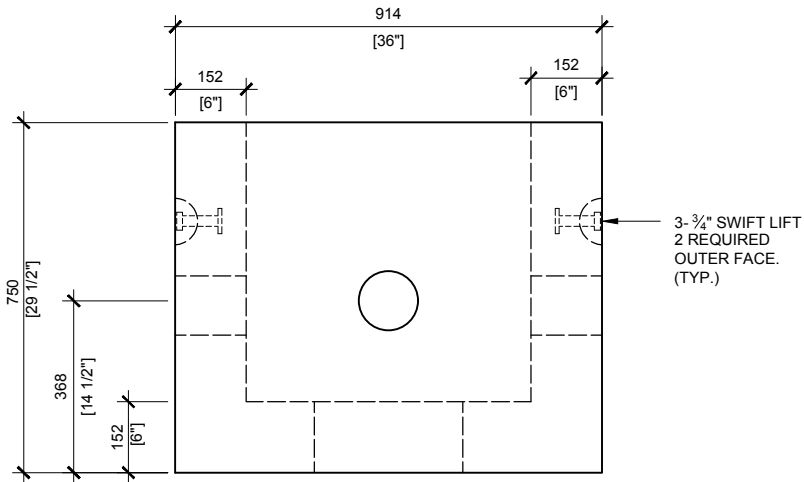

FRONT VIEW
SCALE: 1/16

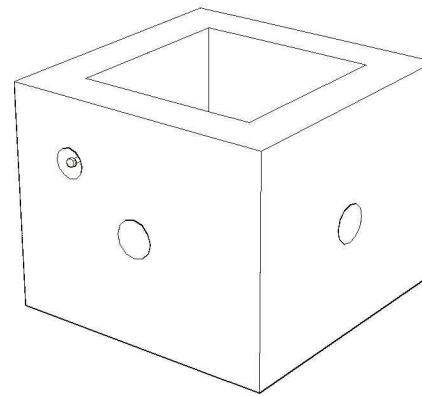

GENERAL NOTES

1. CABLE ENTRY OPENINGS - 5" O.D.
 2. REINFORCEMENT STEEL TO CSA CAN A23 SERIES
 3. DELIVERY IS MADE BY CRANE-EQUIPPED TRUCKS, EXCAVATION MUST BE SAFE AND ACCESSIBLE FOR UNLOADING FROM THE REAR OF THE TRUCK
 4. MINIMUM OVERHEAD CLEARANCE OF 18FT IS REQUIRED
 5. ALL UNITS MUST BE HANDLED WITH PROPER LIFTING EQUIPMENT (I.E. SPREADER BAR)
 6. MINIMUM SOIL BEARING CAPACITY (SLS)=150 KPA.
- * TYPICAL USE WOULD REQUIRE JW150 CAST IRON FRAME AND COVER (OPSD 401.01)



MANUFACTURED:
BROOKLIN, ON
1-800-655-3430

CONCRETE: 335MPa / 5,000PSI
AIR ENTRAINMENT: 6-8%
REINFORCEMENT : STEEL TO CSA CAN
A23.1 / A23.3. G30.18 Fy=400MPa

WEIGHT:
2112.04- 2,000lbs / 915kg

DRAWN BY:
S.RIMLAND

DATE:
AUG/2017

BCP2112.04

PRECAST CONCRETE ELECTRICAL HANDHOLE
MEETS OPSD 2112.040, DESIGNED TO CL-625-ONT LIVE LOADING