

TOP VIEW
SCALE:1/30

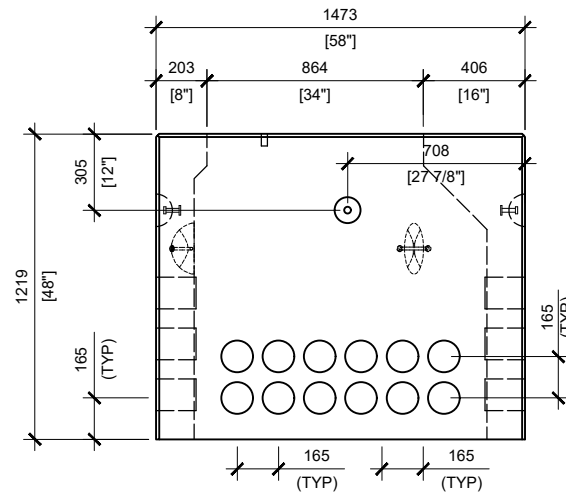

RIGHT VIEW
SCALE:1/30

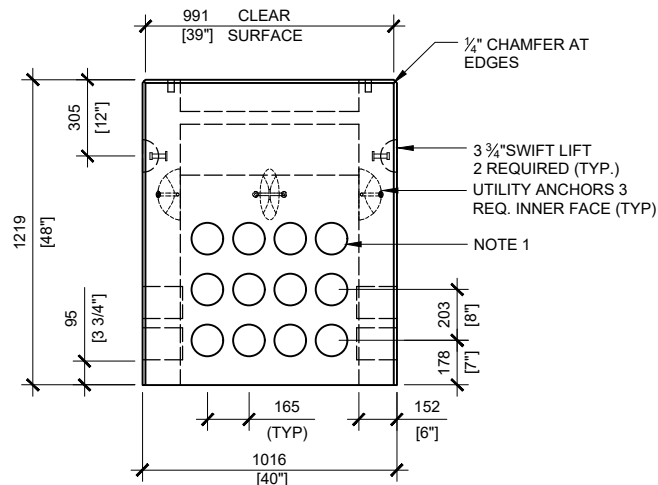
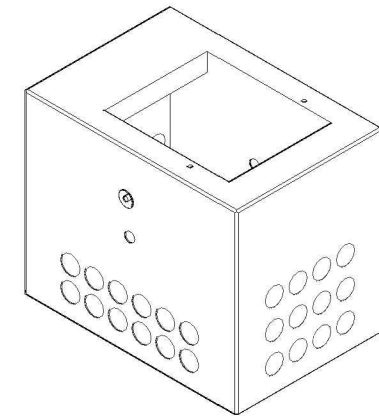

FRONT VIEW
SCALE:1/30

GENERAL NOTES:

1. CABLE ENTRY OPENINGS - 4-3/4" PVC SEALS
2. DELIVERY IS MADE BY CRANE-EQUIPPED TRUCKS
3. EXCAVATION MUST BE READY, SAFE AND ACCESSIBLE FOR UNLOADING FROM THE REAR OF THE TRUCK.
4. MIN OVERHEAD CLEARANCE OF 18FT IS REQUIRED
5. ALL UNITS MUST BE HANDLED WITH PROPER LIFTING EQUIPMENT (I.E. SPREADER BAR)
6. FOR INSTALLATIONS ON STONE BEDDING, THE ALLOWABLE BEARING PRESSURE AT THE UNDERSIDE OF THE VAULT BOX SECTION SHALL BE A MINIMUM OF 150kPa (S.L.S.)
7. THIS BEARING PRESSURE IS ASSUMED AND SHALL BE CONFIRMED BY A QUALIFIED GEOTECHNICAL ENGINEER PRIOR TO INSTALLATION OF THE VAULT
8. THE TRANSFORMER SHOULD BE UNIFORMLY DISTRIBUTED AND THE EDGE OF THE TRANSFORMER BASE SHALL BE SET WITHIN 150MM OF THE INTERIOR DIMENSIONS FOR THE BASE
9. TOP EDGES TO BE CHAMFERED



MANUFACTURED:
BROOKLIN, ON
1-800-655-3430

CONCRETE: 35MPa / 5,000PSI
AIR ENTRAINMENT: 6-8%
REINFORCEMENT : STEEL TO CSA CAN
A23.1 / A23.3. G30.18 Fy=400MPa

WEIGHT:
BCP110PM -4,555lbs / 2,065kg

DRAWN BY:
S.RIMLAND

DATE:
AUG/2017

BCP110PM

FOUNDATION FOR PADMOUNT TRANSFORMER