

BCP111C TOP VIEW
SCALE:1/40

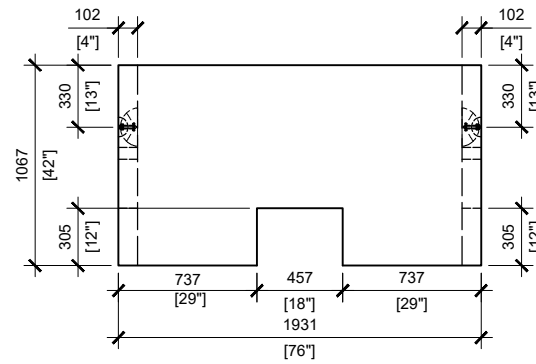

BCP111C FRONT VIEW
SCALE:1/40

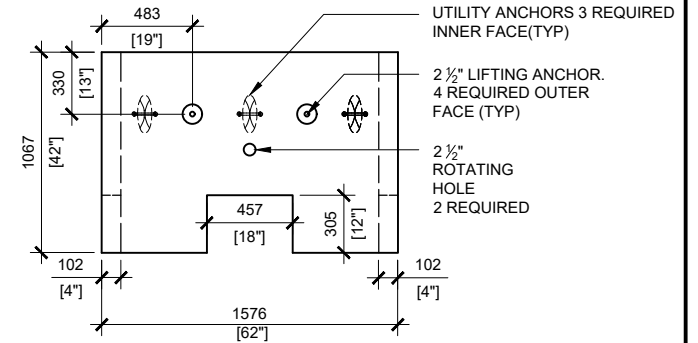

BCP111C RIGHT VIEW
SCALE:1/40

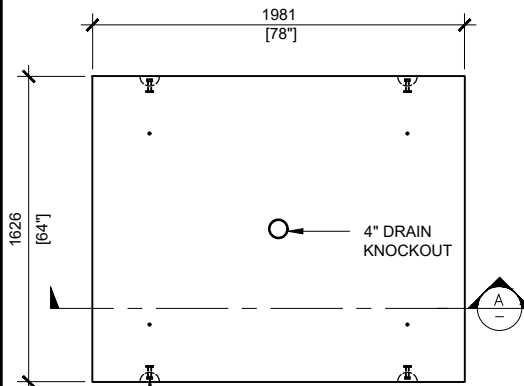

BCP111B TOP VIEW
SCALE:1/40

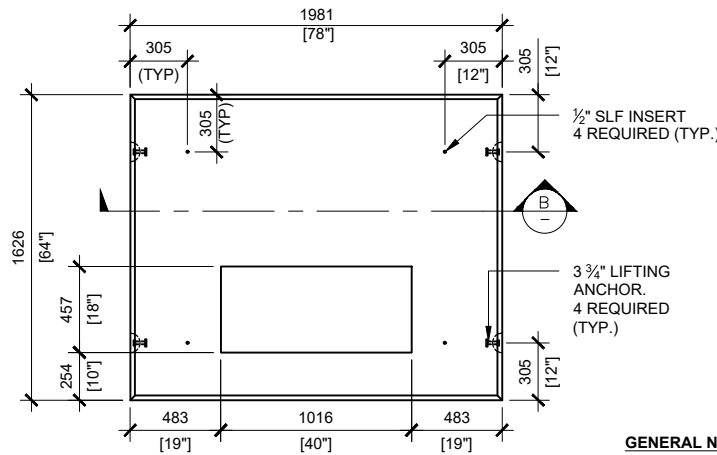

BCP111T TOP VIEW
SCALE:1/40

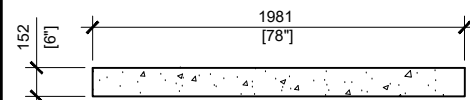
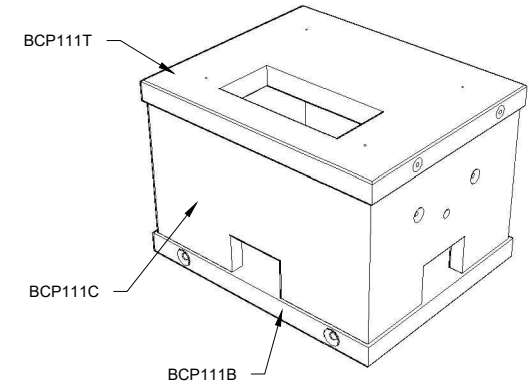

SECTION A
SCALE:1/40

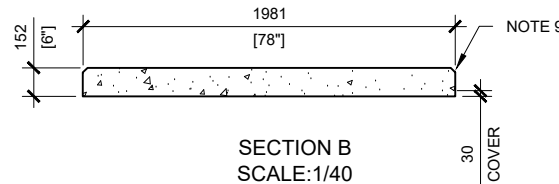

SECTION B
SCALE:1/40

GENERAL NOTES:

- CABLE ENTRY OPENINGS - 4 3/4" PVC SEALS
- DELIVERY IS MADE BY CRANE-EQUIPPED TRUCKS
- EXCAVATION MUST BE READY, SAFE AND ACCESSIBLE FOR UNLOADING FROM THE REAR OF THE TRUCK.
- MIN OVERHEAD CLEARANCE OF 18FT (5.5 METRES) IS REQUIRED
- ALL UNITS MUST BE HANDLED WITH PROPER LIFTING EQUIPMENT (I.E. SPREADER BAR)
- FOR INSTALLATIONS ON STONE BEDDING, THE ALLOWABLE BEARING PRESSURE AT THE UNDERSIDE OF THE VAULT BOX SECTION SHALL BE A MINIMUM OF 75KPA (S.L.S.)
- THIS BEARING PRESSURE IS ASSUMED AND SHALL BE CONFIRMED BY A QUALIFIED GEOTECHNICAL ENGINEER PRIOR TO INSTALLATION OF THE VAULT
- THE TRANSFORMER SHOULD BE UNIFORMLY DISTRIBUTED AND THE EDGE OF THE TRANSFORMER BASE SHALL BE SET WITHIN 150MM OF THE INTERIOR DIMENSIONS FOR THE BASE
- TOP EDGES TO HAVE CHAMFER.



MANUFACTURED:
BROOKLIN, ON
1-800-655-3430

CONCRETE: 35MPa / 5,000PSI
AIR ENTRAINMENT: 5-8%
REINFORCEMENT: STEEL TO CSA CAN
A23.1 / A23.3. G30.18 Fy=400MPa

WEIGHT:
BCP111T -2,200lbs / 1,000kg
BCP111C -3,500lbs / 1,590kg
BCP111B -2,600lbs / 1,120kg

DRAWN BY:
N.CHAN

DATE:
MAY/2020

BCP111HO-01

INCLUDES: BCP111T/ BCP111C / BCP111B