

BCP114PBH20 TOP VIEW
SCALE:1/40

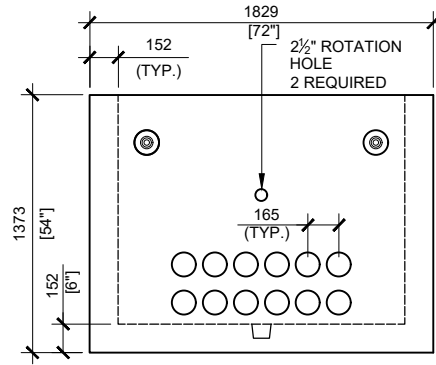

BCP114PBH20 FRONT VIEW
SCALE:1/40

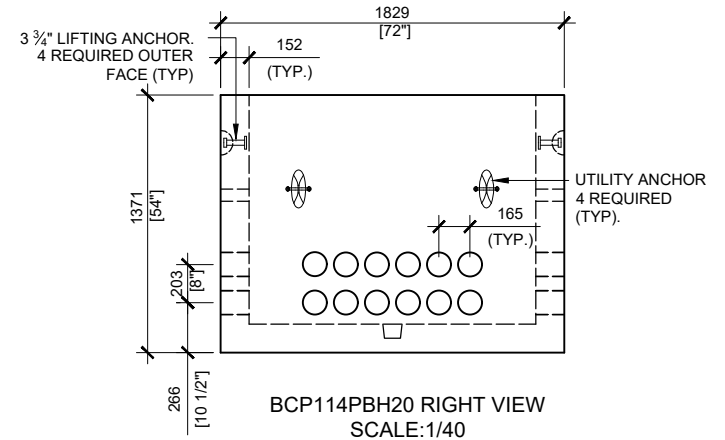

BCP114PBH20 RIGHT VIEW
SCALE:1/40

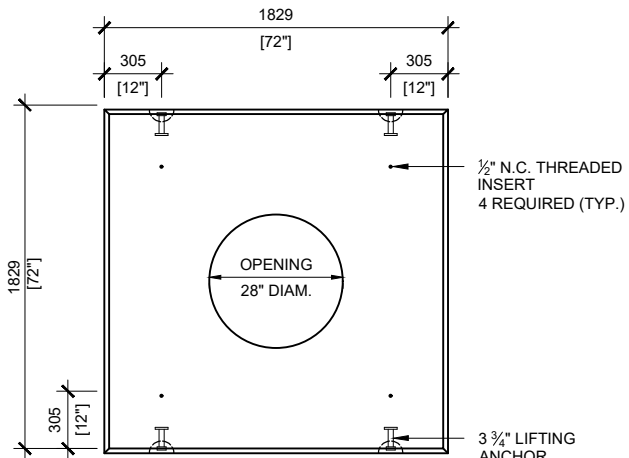

BCP114T9H20 TOP VIEW
SCALE:1/40

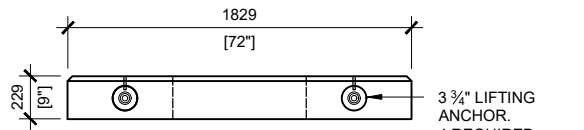

BCP114T9H20 FRONT VIEW
SCALE:1/40

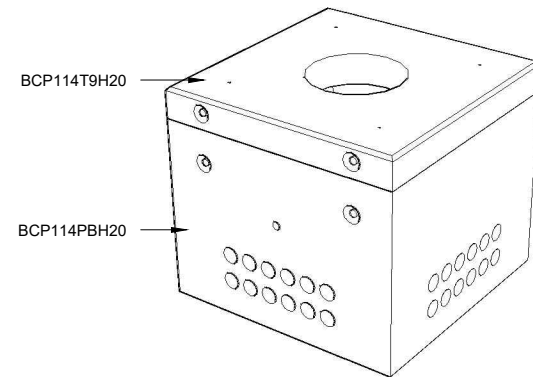

GENERAL NOTES:

1. CABLE ENTRY OPENINGS - 4-3/4" PVC SEALS
2. DELIVERY IS MADE BY CRANE-EQUIPPED TRUCKS
3. EXCAVATION MUST BE READY, SAFE AND ACCESSIBLE FOR UNLOADING FROM THE REAR OF THE TRUCK.
4. MIN OVERHEAD CLEARANCE OF 18FT (5.5 METRES) IS REQUIRED
5. ALL UNITS MUST BE HANDLED WITH PROPER LIFTING EQUIPMENT (I.E. SPREADER BAR)
6. MAXIMUM BURIAL DEPTH 30"

* TYPICAL USE WOULD REQUIRE JW150 CAST IRON FRAME AND COVER (OPSD 401.01)



MANUFACTURED:
BROOKLIN, ON
1-800-655-3430

CONCRETE: 35MPa / 5,000PSI
AIR ENTRAINMENT: 5-8%
REINFORCEMENT : STEEL TO CSA CAN
A23.1 / A23.3. G30.18 Fy=400MPa

WEIGHT:
BCP114T9H20 -3,560lbs / 1,615kg
BCP114PBH20 -8,700lbs / 3,945kg

DRAWN BY:
S.RIMLAND

DATE:
JUL/2020

BCP114H20

PRECAST CONCRETE UTILITY MANHOLE
DESIGNED TO CL-625-ONT TRUCK LIVE LOADING AS PER CSA S6-14