

BCP114PB TOP VIEW
SCALE:1/40

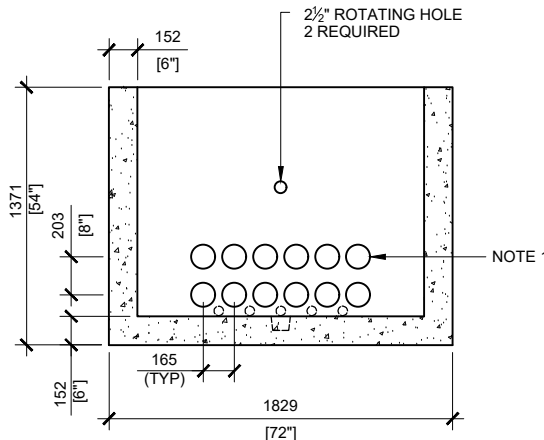

SECTION A
SCALE:1/40

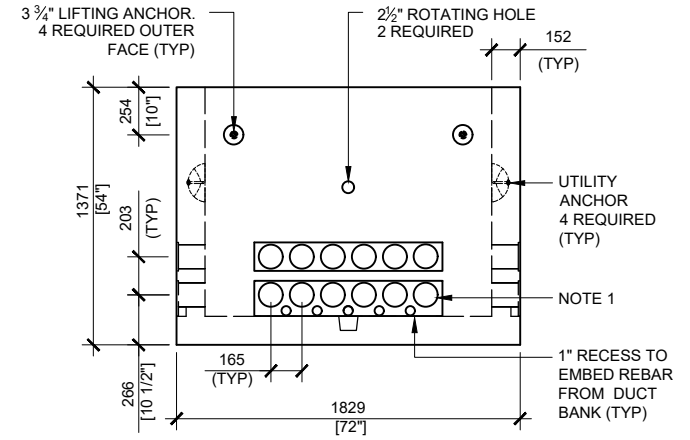

BCP114PB FRONT VIEW
SCALE:1/40

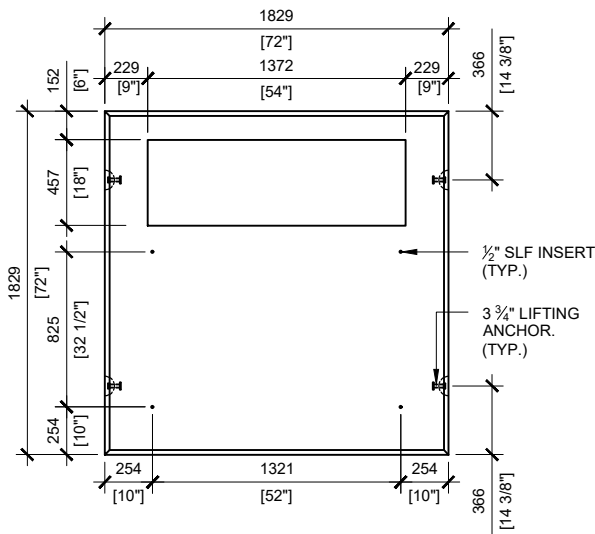

BCP114TBA9 TOP VIEW
SCALE:1/40

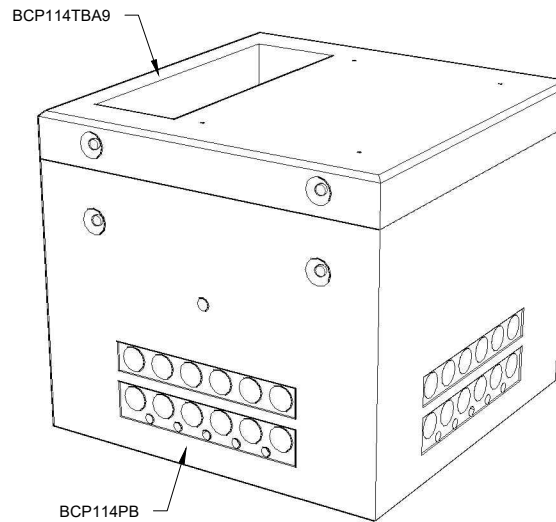

GENERAL NOTES:

1. CABLE ENTRY OPENINGS - 4-3/4"
2. DELIVERY IS MADE BY CRANE-EQUIPPED TRUCKS
3. EXCAVATION MUST BE READY, SAFE AND ACCESSIBLE FOR UNLOADING FROM THE REAR OF THE TRUCK.
4. MIN OVERHEAD CLEARANCE OF 18FT (5.5 METRES) IS REQUIRED
5. ALL UNITS MUST BE HANDLED WITH PROPER LIFTING EQUIPMENT (I.E. SPREADER BAR)
6. FOR INSTALLATIONS ON STONE BEDDING, THE ALLOWABLE BEARING PRESSURE AT THE UNDERSIDE OF THE VAULT BOX SECTION SHALL BE A MINIMUM OF 75 KPA (S.L.S.)
7. THIS BEARING PRESSURE IS ASSUMED AND SHALL BE CONFIRMED BY A QUALIFIED GEOTECHNICAL ENGINEER PRIOR TO INSTALLATION OF THE VAULT
8. THE TRANSFORMER SHOULD BE UNIFORMLY DISTRIBUTED AND THE EDGE OF THE TRANSFORMER BASE SHALL BE SET WITHIN 150MM OF THE INTERIOR DIMENSIONS FOR THE BASE
9. TOP EDGES TO HAVE CHAMFER



MANUFACTURED:
BROOKLIN, ON
1-800-655-3430

CONCRETE: 35MPa / 5,000PSI
AIR ENTRAINMENT: 5-8%
REINFORCEMENT: STEEL TO CSA
CAN A23.1 / A23.3. G30.18 Fy=400MPa

WEIGHT:
BCP114TBA9 -3,270lbs / 1,480kg
BCP114PB -8,700lbs / 3,945kg

DRAWN BY:
N.CHAN

DATE:
JUN/2020

BCP114HO-03

INCLUDES: BCP114TBA9/ BCP114PB