

GENERAL NOTES:

1. DELIVERY IS MADE BY CRANE-EQUIPPED TRUCKS
2. EXCAVATION MUST BE READY, SAFE AND ACCESSIBLE FOR UNLOADING FROM THE REAR OF THE TRUCK.
3. MIN OVERHEAD CLEARANCE OF 18FT (5.5 METRES) IS REQUIRED
4. ALL UNITS MUST BE HANDLED WITH PROPER LIFTING EQUIPMENT (I.E. SPREADER BAR)
5. TOP SURFACE TO HAVE BRUSH FINISH

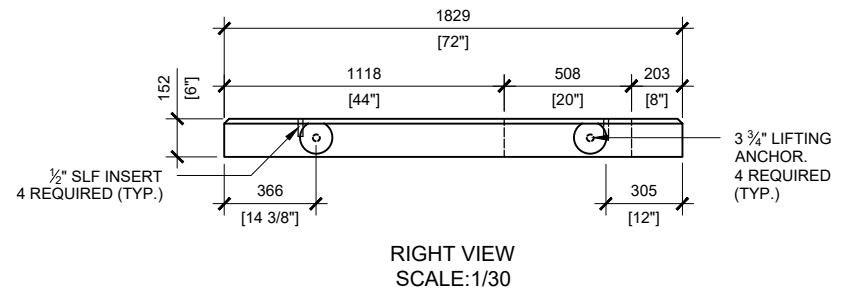
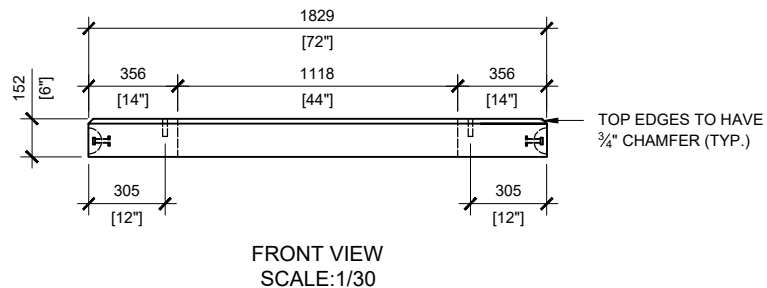
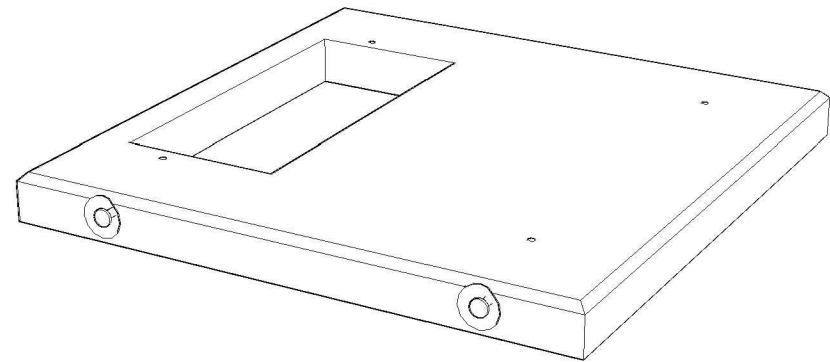

MANUFACTURED:
 BROOKLIN, ON
 1-800-655-3430

CONCRETE: 35MPa / 5,000PSI
 AIR ENTRAINMENT: 5-8%
 REINFORCEMENT : STEEL TO CSA CAN
 A23.1 / A23.3. G30.18 Fy=400MPa

WEIGHT:
 BCP114T6 -2,280lbs / 1,036kg

DRAWN BY:
 N.CHAN

DATE:
 JAN/2021

BCP114T6

PRECAST TOP FOR PADMOUNT TRANSFORMER