

TOP VIEW  
SCALE: 1/30

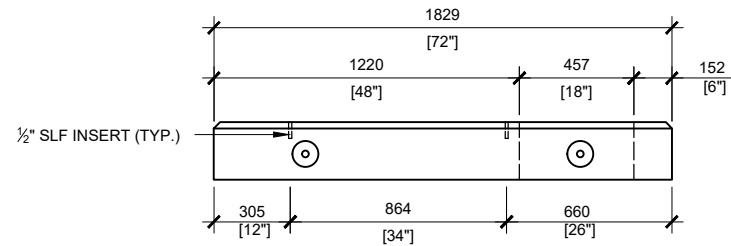

RIGHT VIEW  
SCALE: 1/30

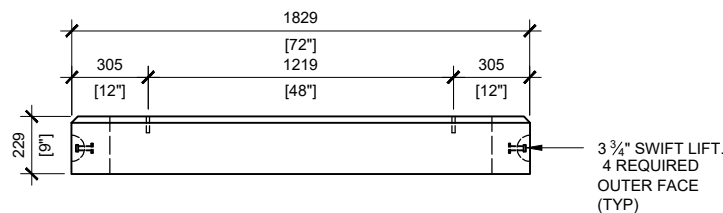
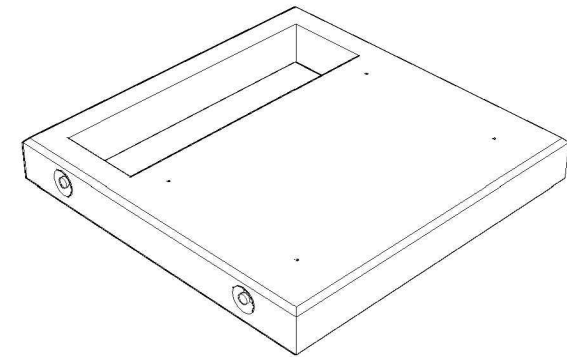

FRONT VIEW  
SCALE: 1/30

**GENERAL NOTES:**

1. DELIVERY IS MADE BY CRANE-EQUIPPED TRUCKS
2. EXCAVATION MUST BE READY, SAFE AND ACCESSIBLE FOR UNLOADING FROM THE REAR OF THE TRUCK.
3. MIN OVERHEAD CLEARANCE OF 18FT IS REQUIRED
4. ALL UNITS MUST BE HANDLED WITH PROPER LIFTING EQUIPMENT (I.E. SPREADER BAR)
5. FOR INSTALLATIONS ON STONE BEDDING, THE ALLOWABLE BEARING PRESSURE AT THE UNDERSIDE OF THE VAULT BOX SECTION SHALL BE A MINIMUM OF 150KPA (S.L.S.)
6. THIS BEARING PRESSURE IS ASSUMED AND SHALL BE CONFIRMED BY A QUALIFIED GEOTECHNICAL ENGINEER PRIOR TO INSTALLATION OF THE VAULT
7. THE TRANSFORMER SHOULD BE UNIFORMLY DISTRIBUTED AND THE EDGE OF THE TRANSFORMER BASE SHALL BE SET WITHIN 150MM OF THE INTERIOR DIMENSIONS FOR THE BASE



MANUFACTURED:  
BROOKLIN, ON  
1-800-655-3430

CONCRETE: 35MPa / 5,000PSI  
AIR ENTRAINMENT: 6-8%  
REINFORCEMENT : STEEL TO CSA  
CAN A23.1 / A23.3. G30.18  
Fy=400MPa

WEIGHT:  
BCP114TBB9 -3,185lbs / 1,445kg

DRAWN BY:  
S.RIMLAND

DATE:  
AUG/2017

**BCP114TBB9**

PRECAST TOP FOR TRANSFORMER FOUNDATION