

TOP VIEW
SCALE: 1/20

GENERAL NOTES:

1. DELIVERY IS MADE BY CRANE-EQUIPPED TRUCKS
2. EXCAVATION MUST BE READY, SAFE AND ACCESSIBLE FOR UNLOADING FROM THE REAR OF THE TRUCK.
3. MIN OVERHEAD CLEARANCE OF 18FT (5.5 METRES) IS REQUIRED
4. ALL UNITS MUST BE HANDLED WITH PROPER LIFTING EQUIPMENT (I.E. SPREADER BAR)

MODIFIED AS REQUIRED

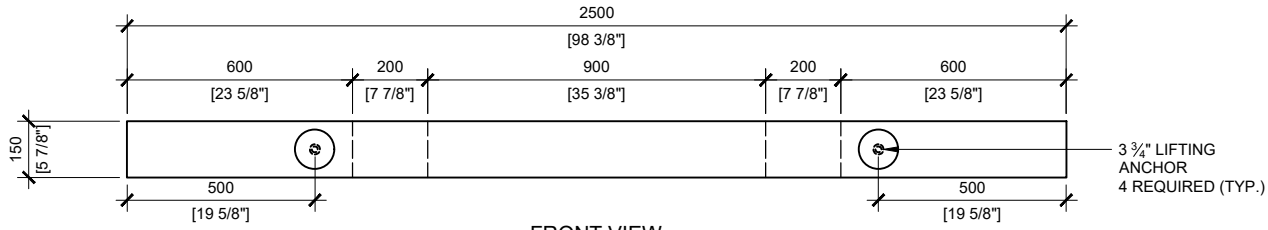
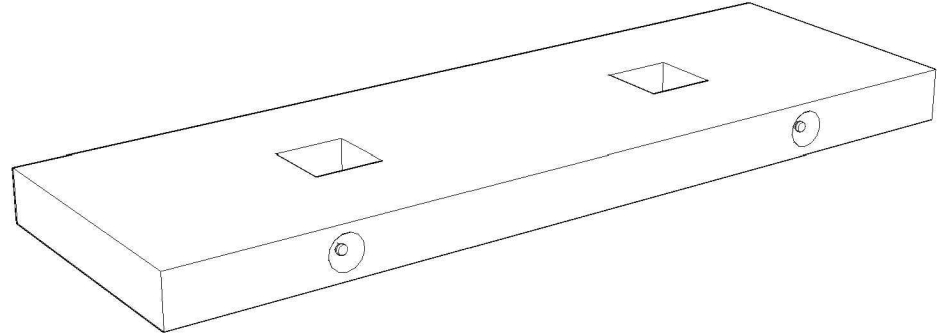

FRONT VIEW
SCALE: 1/20

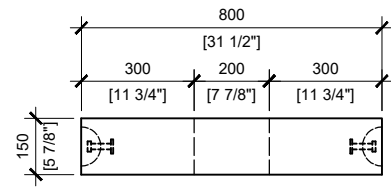

RIGHT VIEW
SCALE: 1/20



MANUFACTURED:
BROOKLIN, ON
1-800-655-3430

CONCRETE: 35MPa / 5,000PSI
AIR ENTRAINMENT: 5-8%
REINFORCEMENT : STEEL TO CSA CAN
A23.1 / A23.3. G30.18 Fy=400MPa

WEIGHT:
BCP201EV - 1,564lbs / 709kg

DRAWN BY:
N.CHAN
DATE:
FEB/2021

BCP202EV

PRECAST SLAB FOR ELECTRIC VEHICLE CHARGING STATIONS