

TOP VIEW  
SCALE:1/20

- GENERAL NOTES:**
1. DELIVERY IS MADE BY CRANE-EQUIPPED TRUCKS
  2. EXCAVATION MUST BE READY, SAFE AND ACCESSIBLE FOR UNLOADING FROM THE REAR OF THE TRUCK.
  3. MIN OVERHEAD CLEARANCE OF 18FT (5.5 METRES) IS REQUIRED
  4. ALL UNITS MUST BE HANDLED WITH PROPER LIFTING EQUIPMENT (I.E. SPREADER BAR)

**\*MODIFIED AS REQUIRED\***

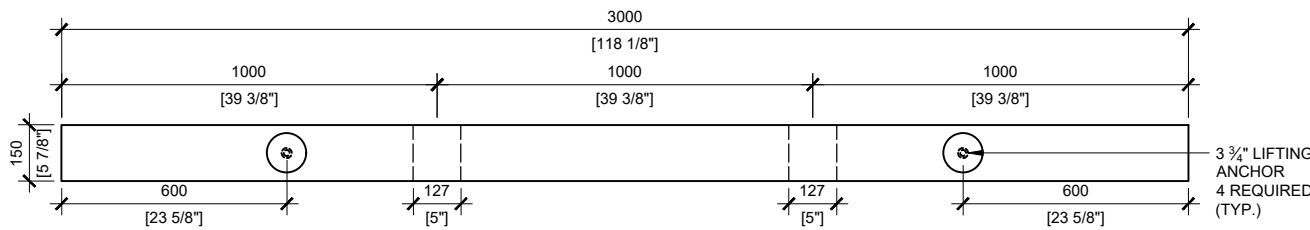
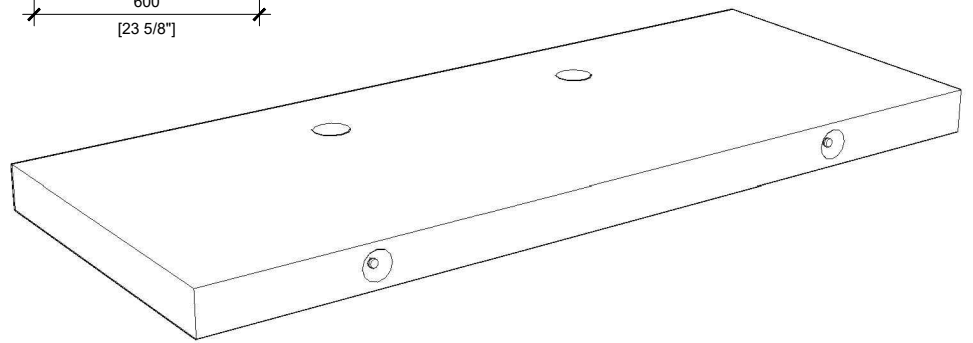

FRONT VIEW  
SCALE:1/20

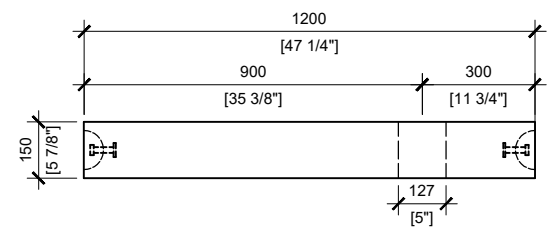

RIGHT VIEW  
SCALE:1/20



MANUFACTURED:  
BROOKLIN, ON  
1-800-655-3430

CONCRETE: 35MPa / 5,000PSI  
AIR ENTRAINMENT: 5-8%  
REINFORCEMENT : STEEL TO CSA CAN  
A23.1 / A23.3. G30.18 Fy=400MPa

WEIGHT:  
BCP203EV - 2,922lbs / 1,325kg

DRAWN BY:  
N.CHAN  
DATE:  
FEB/2021

**BCP203EV**  
PRECAST SLAB FOR ELECTRIC VEHICLE CHARGING STATIONS