

TOP VIEW  
SCALE:1/30

**GENERAL NOTES:**

1. DELIVERY IS MADE BY CRANE-EQUIPPED TRUCKS
2. EXCAVATION MUST BE READY, SAFE AND ACCESSIBLE FOR UNLOADING FROM THE REAR OF THE TRUCK.
3. MIN OVERHEAD CLEARANCE OF 18FT (5.5 METRES) IS REQUIRED
4. ALL UNITS MUST BE HANDLED WITH PROPER LIFTING EQUIPMENT (I.E. SPREADER BAR)

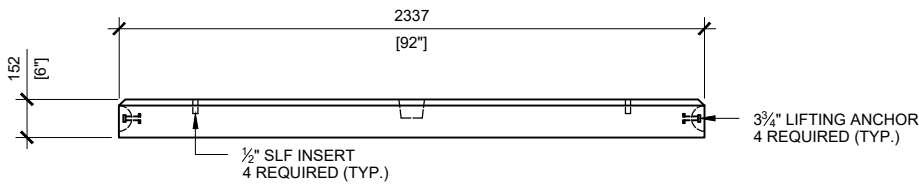
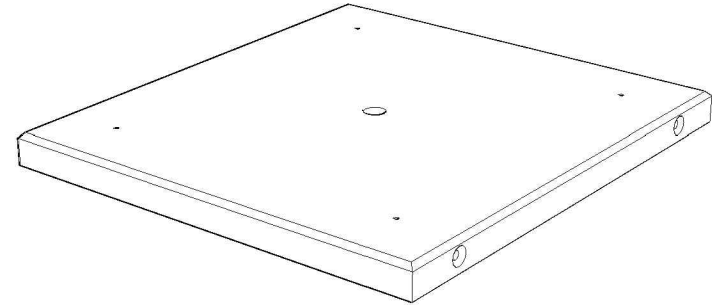

FRONT VIEW  
SCALE:1/30

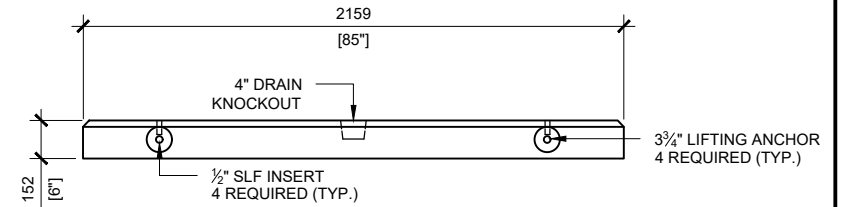

RIGHT VIEW  
SCALE:1/30



**MANUFACTURED:**  
BROOKLIN, ON  
1-800-655-3430

**CONCRETE:** 35MPa / 5,000PSI  
**AIR ENTRAINMENT:** 5-8%  
**REINFORCEMENT :** STEEL TO CSA CAN  
A23.1 / A23.3. G30.18 Fy=400MPa

**WEIGHT:**  
BCP 400B -4,025lbs / 1,830kg

**DRAWN BY:**  
N.CHAN

**DATE:**  
MAY/2020

**BCP400B**

BASE FOR PRECAST FOUNDATION