

TOP VIEW  
SCALE:1/30

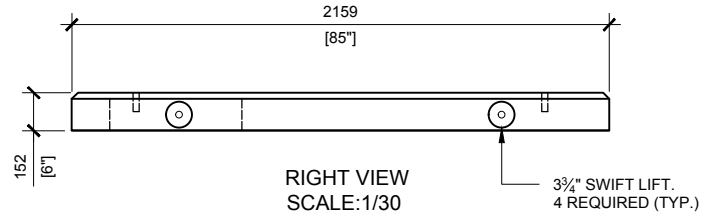

RIGHT VIEW  
SCALE:1/30

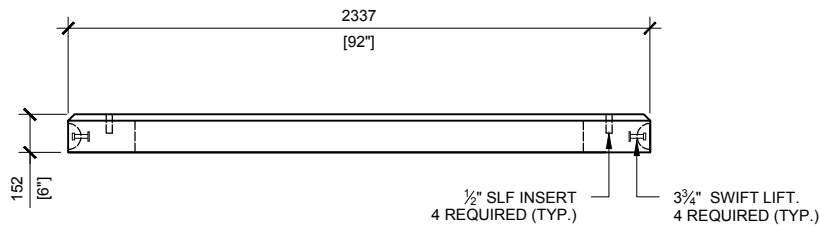
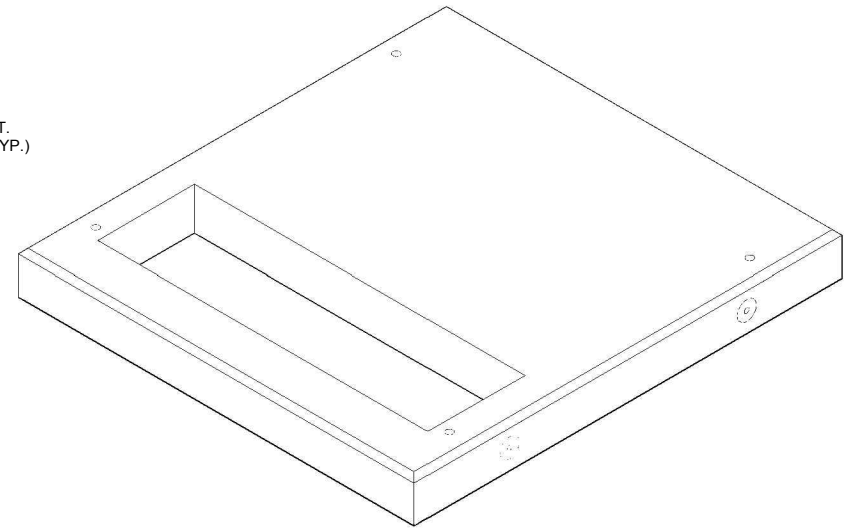

FRONT VIEW  
SCALE:1/30

**GENERAL NOTES:**

1. DELIVERY IS MADE BY CRANE-EQUIPPED TRUCKS
2. EXCAVATION MUST BE READY, SAFE AND ACCESSIBLE FOR UNLOADING FROM THE REAR OF THE TRUCK.
3. MIN OVERHEAD CLEARANCE OF 18FT IS REQUIRED
4. ALL UNITS MUST BE HANDLED WITH PROPER LIFTING EQUIPMENT (I.E. SPREADER BAR)



MANUFACTURED:  
BROOKLIN, ON  
1-800-655-3430

CONCRETE: 35MPa / 4600PSI  
AIR ENTRAINMENT: 6-8%  
REINFORCEMENT : STEEL TO CSA CAN  
A23.1 / A23.3. G30.18 Fy=400MPa

WEIGHT:  
BCP 400T6 -3,280lbs / 1,487kg

DRAWN BY:  
S.RIMLAND

DATE:  
AUG/2017

**BCP400T6**

PRECAST LID FOR PADMOUNT FOUNDATION