

TOP VIEW
SCALE:1/30

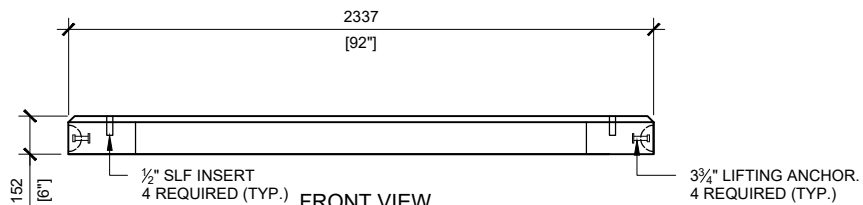

FRONT VIEW
SCALE:1/30

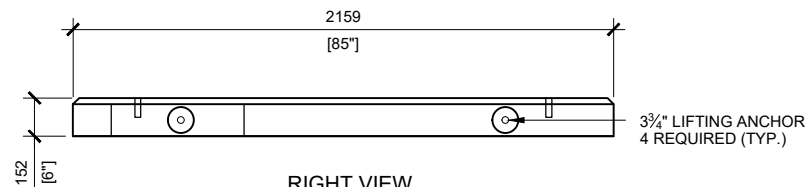
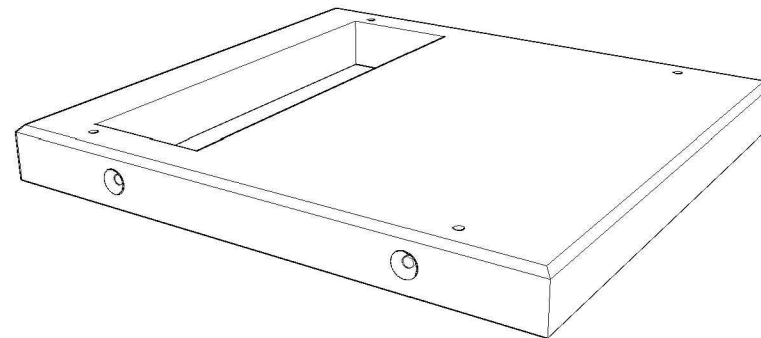

RIGHT VIEW
SCALE:1/30

GENERAL NOTES:

1. DELIVERY IS MADE BY CRANE-EQUIPPED TRUCKS
2. EXCAVATION MUST BE READY, SAFE AND ACCESSIBLE FOR UNLOADING FROM THE REAR OF THE TRUCK.
3. MIN OVERHEAD CLEARANCE OF 18FT (5.5 METRES) IS REQUIRED
4. ALL UNITS MUST BE HANDLED WITH PROPER LIFTING EQUIPMENT (I.E. SPREADER BAR)



MANUFACTURED:
BROOKLIN, ON
1-800-655-3430

CONCRETE: 35MPa / 4800PSI
AIR ENTRAINMENT: 5-8%
REINFORCEMENT : STEEL TO CSA CAN
A23.1 / A23.3. G30.18 Fy=400MPa

WEIGHT:
BCP 400T6 -3,280lbs / 1,487kg

DRAWN BY:
N.CHAN

DATE:
MAY/2020

BCP400T6

PRECAST LID FOR PADMOUNT FOUNDATION