

TOP VIEW
SCALE:1/30

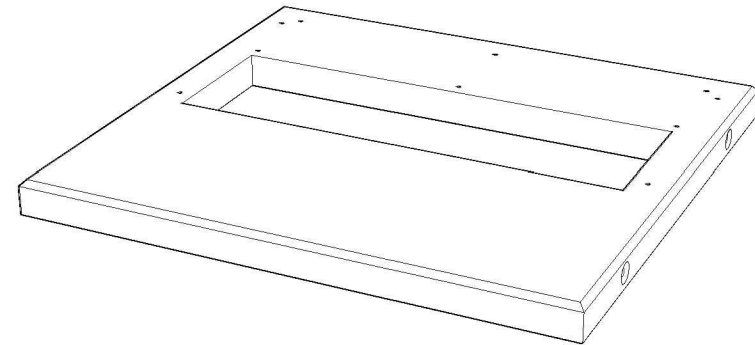

GENERAL NOTES:

1. DELIVERY IS MADE BY CRANE-EQUIPPED TRUCKS
2. EXCAVATION MUST BE READY, SAFE AND ACCESSIBLE FOR UNLOADING FROM THE REAR OF THE TRUCK.
3. MIN OVERHEAD CLEARANCE OF 18FT (5.5 METRES) IS REQUIRED
4. ALL UNITS MUST BE HANDLED WITH PROPER LIFTING EQUIPMENT (I.E. SPREADER BAR)
5. TOP EDGES TO HAVE CHAMFER

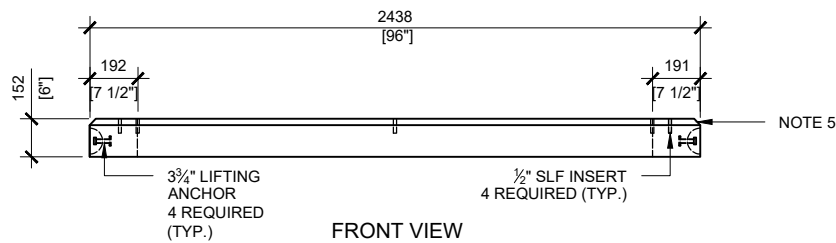

FRONT VIEW
SCALE:1/30

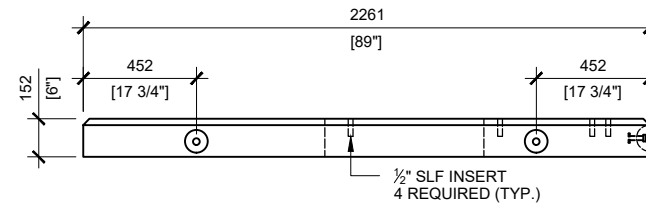

RIGHT VIEW
SCALE:1/30



MANUFACTURED:
BROOKLIN, ON
1-800-655-3430

CONCRETE: 35MPa / 5,000PSI
AIR ENTRAINMENT: 5-8%
REINFORCEMENT : STEEL TO CSA
CAN A23.1 / A23.3, G30.18
Fy=400MPa

WEIGHT:
BCP 400TGWHO -3,400lbs / 1,540kg

DRAWN BY:
N.CHAN

DATE:
MAY/2020

BCP400T6GWHO

PRECAST TOP FOR TRANSFORMER FOUNDATION