

FRONT VIEW
SCALE:1/16

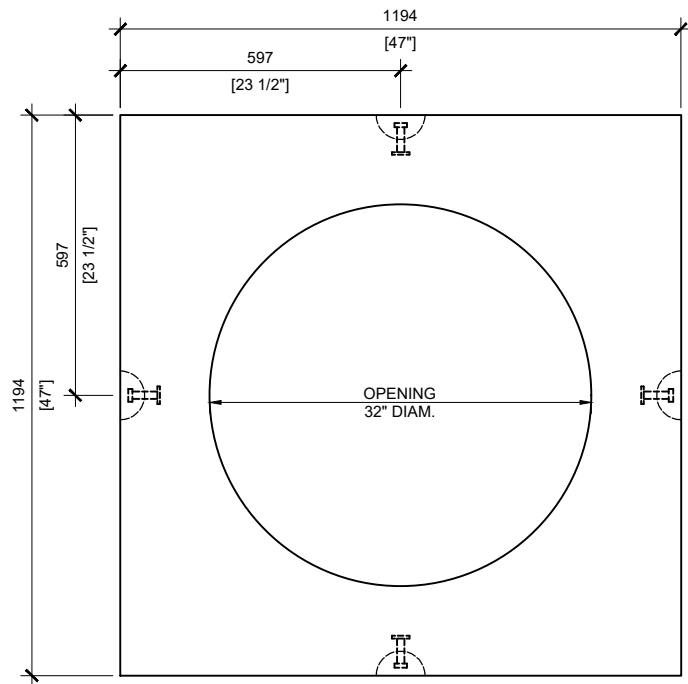

TOP VIEW
SCALE:1/16

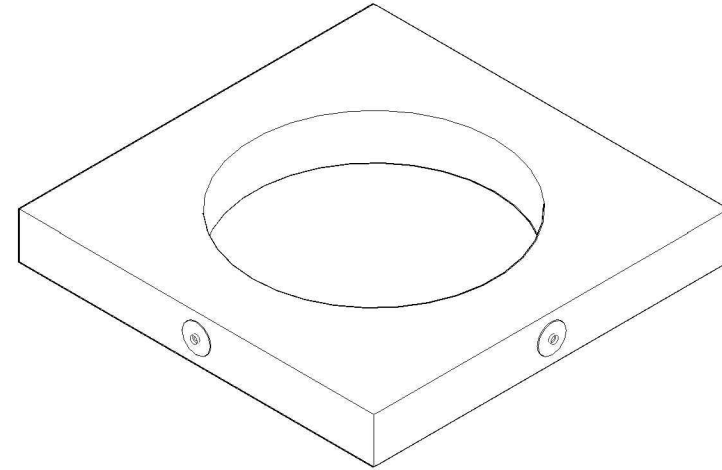

GENERAL NOTES:

1. CONCRETE COVER TO BE 35mm EXTERNAL FACE / 25mm INTERNAL FACE
 2. ALL UNITS MUST BE HANDLED WITH PROPER LIFTING EQUIPMENT
 3. FOR H2O MANHOLES STACK UP TO FOUR RISERS
 4. PROVIDE TYPE "S" MORTAR BETWEEN RISERS
 5. JOINTS SHALL BE SEALED WITH FLEXIBLE WATERTIGHT RUBBER GASKETS
- * TYPICAL USE WOULD REQUIRE JW500 CAST IRON FRAME AND COVER



MANUFACTURED:
BROOKLIN, ON
1-800-655-3430

CONCRETE: 35MPa / 5,000PSI
AIR ENTRAINMENT: 6-8%
REINFORCEMENT : STEEL TO CSA CAN
A23.1 / A23.3. G30.18 Fy=400MPa

WEIGHT:
BCP RISER- 649lbs / 294kg

DRAWN BY:
S.RIMLAND

DATE:
AUG/2017

BCP RISER 6"

PRECAST CONCRETE RISER