

BTT-2750-BCP PRIMARY TREATMENT

POS.	ITEM #	DESCRIPTION	QUANTITY
1	413570	BTT-2750-BCP PRIMARY TREATMENT	1
2	408167	POLYLOK PLASTIC RISER 24"dia X 6"h	2
3	450027	POLYLOK LID 24"dia - DOMED	2
4	408041	4" PVC TEE	1
5	408144	TUF-TITE EFFLUENT FILTER 6" C/W T-BAFF	1
6	408038	4 x 10" SOLID SEWER PIPE	3
7	112167	4" CAST.A.SEAL #452.0450	2
8	112622	4" CAST.A.SEAL #452.0450 (CLOSED FACE)	2

- GENERAL NOTES:**
- UNITS ARE SEALED WITH BUTYL TAPE AT THE JOINTS
 - DELIVERY IS MADE BY CRANE-EQUIPPED TRUCKS
 - EXCAVATION MUST BE READY, SAFE AND ACCESSIBLE FOR UNLOADING FROM THE REAR OF THE TRUCK.
 - MIN OVERHEAD CLEARANCE OF 18FT (5.5 METRES) IS REQUIRED
 - ALL UNITS MUST BE HANDLED WITH PROPER LIFTING EQUIPMENT
 - MAXIMUM BURIAL DEPTH = 1 METRE IN FIRM SOIL AWAY FROM ANY VEHICULAR TRAFFIC
 - MUST BE SHIPPED WITH "BTT - 2750 REACTOR"

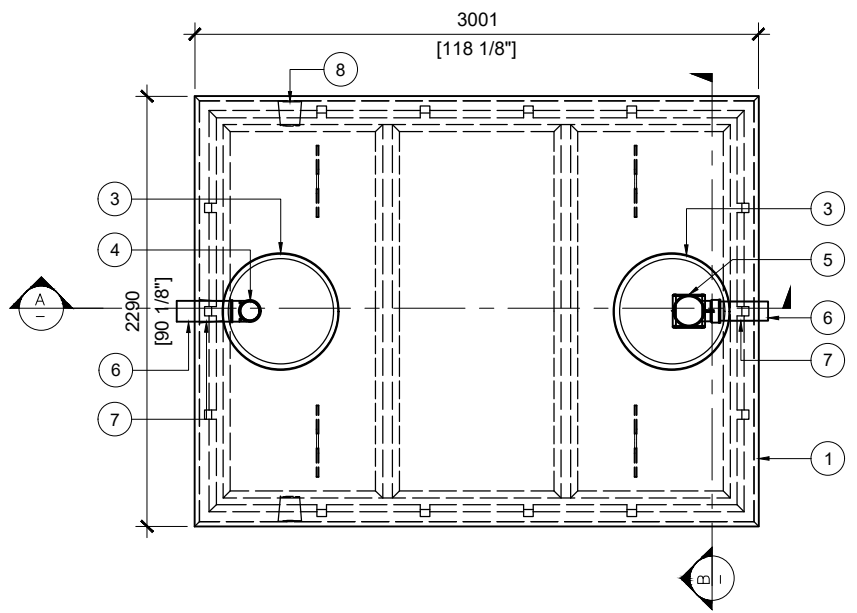

TOP VIEW
SCALE:1/40

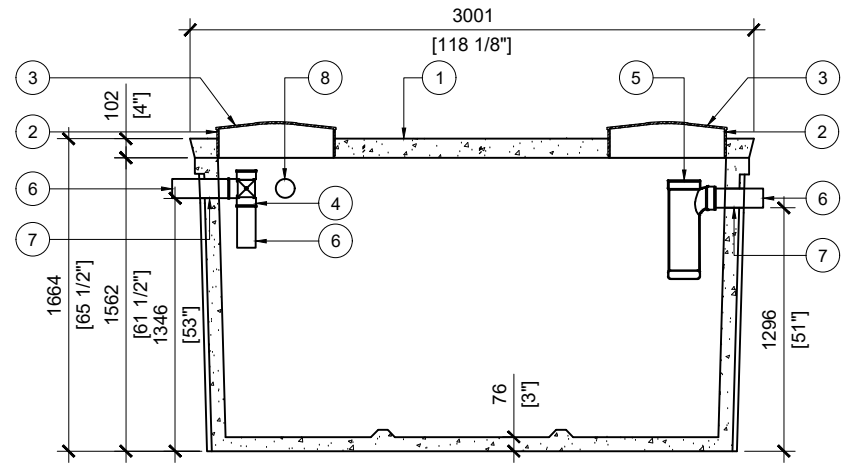

SECTION A
SCALE:1/40

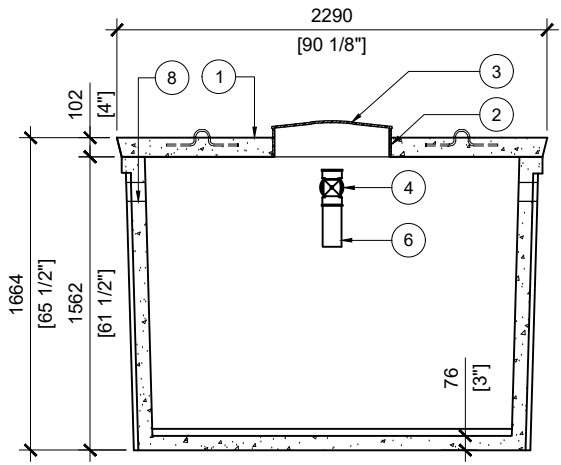

SECTION B
SCALE:1/40



MANUFACTURED:
BROOKLIN, ON
1-800-655-3430

CONCRETE: 35MPa at 28 days/5000PSI
AIR ENTRAINMENT: 5-8%
REINFORCEMENT: STEEL TO CSA CAN
A23.1 /A23.3 G30.18 Fy=400MPa

UNIT WEIGHT: 13,400lbs / 6,080kg
MEETS CAN/CSA-B66
BNQ CERTIFIED

DRAWN BY:
N.CHAN
DATE:
APR/2020

BTT-2750-BCP PRIMARY TREATMENT
6135L / 1350 IMPERIAL GAL. BIONEST TANK
WORKING CAPACITY: 6292L TO INVERT OF OUTLET
TOTAL CAPACITY: 7711L TO UNDERSIDE OF CHAMBER LID