

TOP VIEW
SCALE:1/30

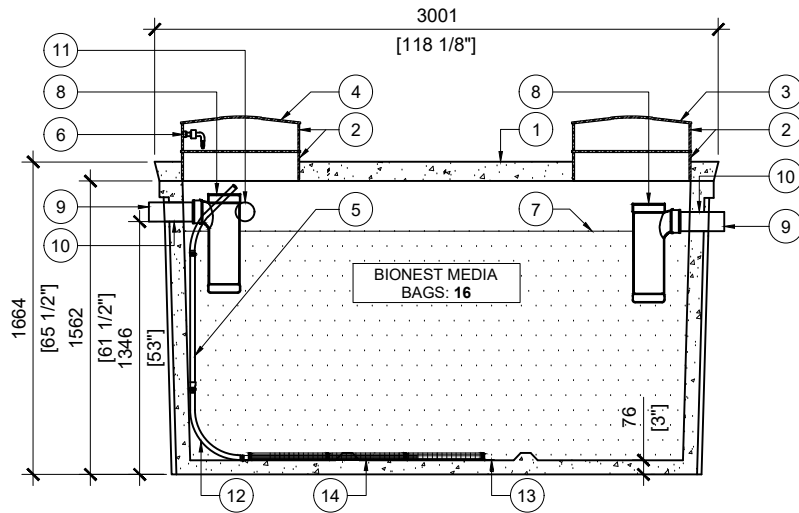

SECTION A
SCALE:1/30

BTT-2750-BCP REACTOR

POS.	ITEM #	DESCRIPTION	QUANTITY
1	413571	BTT-2750-BCP BIONEST REACTOR	1
2	408167	POLYLOK PLASTIC RISER 24" dia X 6"h	4
3	450046	POLYLOK LID 24" dia - VENTED COVER	1
4	450046	POLYLOK LID 24" dia - DOMED	1
5	*SUPPLIED BY BIONEST*	FLEXIBLE AIR DIFFUSER (1.3m)	1
6	*SUPPLIED BY BIONEST*	AIR LINE PIPE	1
7	*SUPPLIED BY BIONEST*	BIONEST MEDIA BAG	16
8	408144	TUF-TITE EF-6" T-BAFFLE	2
9	408038	4 x 10" SOLID SEWER PIPE	2
10	112167	4" CAST.A.SEAL #452.0450	2
11	112622	4" CAST.A.SEAL #452.0450 (CLOSED FACE)	2
12	*SUPPLIED BY BIONEST*	Ø1-1/2" PVC ELBOW 90° BELL-END TO FACE UPWARD	1
13	*SUPPLIED BY BIONEST*	ABS PLASTIC STRIPS 5" x 24"	3
14	*SUPPLIED BY BIONEST*	AIR DIFFUSER CAGE 3.5" x 23"	3

GENERAL NOTES:

1. UNITS ARE SEALED WITH BUTYL TAPE AT THE JOINTS
2. DELIVERY IS MADE BY CRANE-EQUIPPED TRUCKS
3. EXCAVATION MUST BE READY, SAFE AND ACCESSIBLE FOR UNLOADING FROM THE REAR OF THE TRUCK.
4. MIN OVERHEAD CLEARANCE OF 18FT (5.5 METRES) IS REQUIRED
5. ALL UNITS MUST BE HANDLED WITH PROPER LIFTING EQUIPMENT
6. MAXIMUM BURIAL DEPTH = 1 METRE IN FIRM SOIL AWAY FROM ANY VEHICULAR TRAFFIC

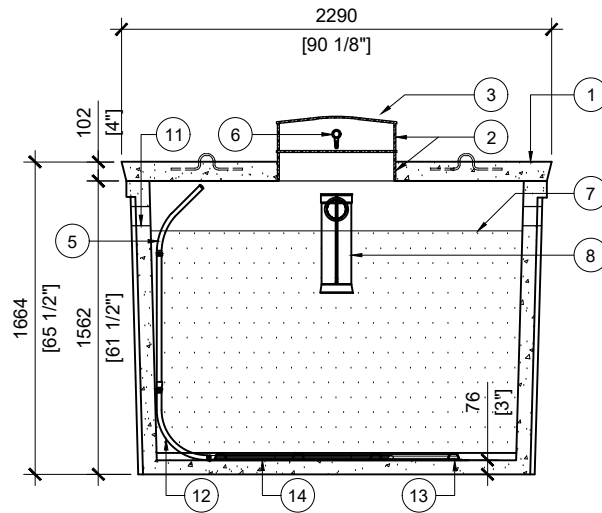

SECTION B
SCALE:1/30



MANUFACTURED:
BROOKLIN, ON
1-800-655-3430

CONCRETE: 35MPa at 28 days/5000PSI
AIR ENTRAINMENT: 5-8%
REINFORCEMENT: STEEL TO CSA CAN
A23.1 /A23.3 G30.18 Fy=400MPa

UNIT WEIGHT: 13,400lbs / 6,080kg
MEETS CAN/CSA-B66
BNQ CERTIFIED

DRAWN BY:
N.CHAN
DATE:
APR/2020

BTT-2750-BCP BIONEST REACTOR
6135L / 1350 IMPERIAL GAL. BIONEST TANK
WORKING CAPACITY: 6292L TO INVERT OF OUTLET
TOTAL CAPACITY: 7711L TO UNDERSIDE OF CHAMBER LID