

TOP VIEW  
SCALE: 1/40

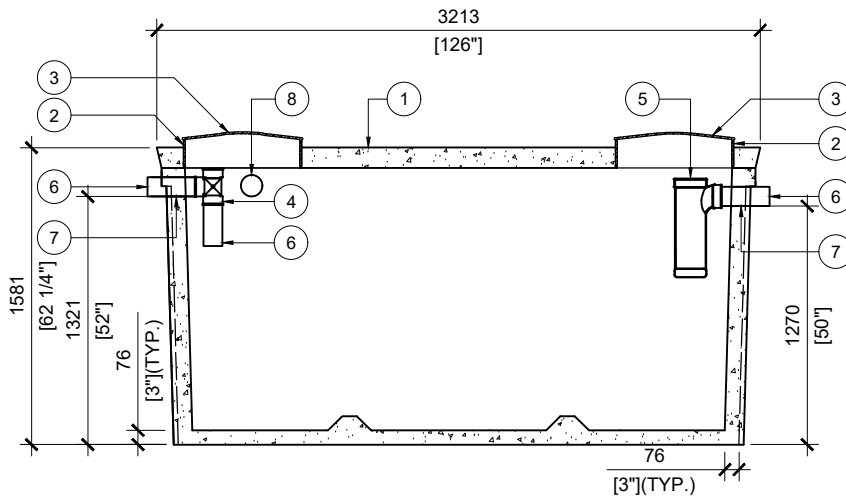

SECTION A  
SCALE: 1/40

### BTT-3400-BCP PRIMARY TREATMENT

POS.	ITEM #	DESCRIPTION	QUANTITY
1	413572	BTT-3400-BCP PRIMARY TREATMENT	1
2	408167	POLYLOK PLASTIC RISER 24"dia X 6"h	2
3	450027	POLYLOK LID 24"dia - DOMED	2
4	408041	4" PVC TEE	1
5	408144	TUF-TITE EFFLUENT FILTER 6" CW T-BAFF	1
6	408038	4 x 10" SOLID SEWER PIPE	3
7	112167	4" CAST.A.SEAL #452.0450	2
8	112622	4" CAST.A.SEAL #452.0450 (CLOSED FACE)	2

**GENERAL NOTES:**

1. UNITS ARE SEALED WITH BUTYL TAPE AT THE JOINTS
2. DELIVERY IS MADE BY CRANE-EQUIPPED TRUCKS
3. EXCAVATION MUST BE READY, SAFE AND ACCESSIBLE FOR UNLOADING FROM THE REAR OF THE TRUCK.
4. MIN OVERHEAD CLEARANCE OF 18FT (5.5 METRES) IS REQUIRED
5. ALL UNITS MUST BE HANDLED WITH PROPER LIFTING EQUIPMENT
6. MAXIMUM BURIAL DEPTH = 1 METRE IN FIRM SOIL AWAY FROM ANY VEHICULAR TRAFFIC
7. MUST BE SHIPPED WITH "BTT - 3400 REACTOR"

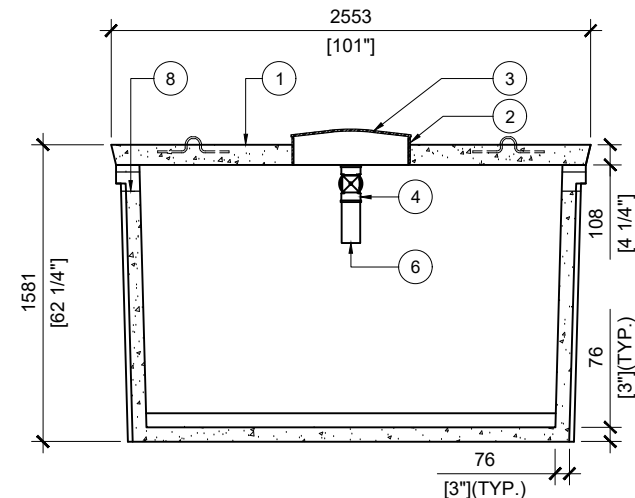

SECTION B  
SCALE: 1/40



MANUFACTURED:  
BROOKLIN, ON  
1-800-655-3430

CONCRETE: 35MPa at 28 days/5000PSI  
AIR ENTRAINMENT: 5-8%  
REINFORCEMENT: STEEL TO CSA CAN  
A23.1 /A23.3 G30.18 Fy=400MPa

UNIT WEIGHT: 14,460lbs / 6,560kg  
MEETS CAN/CSA-B66  
BNQ CERTIFIED

DRAWN BY:  
N.CHAN

DATE:  
APR/2020

BTT-3400-BCP PRIMARY TREATMENT  
7000L / 1550 IMPERIAL GAL. BIONEST TANK

WORKING CAPACITY: 7566L TO INVERT OF INLET  
TOTAL CAPACITY: 8892L TO UNDERSIDE OF CHAMBER LID