

**GENERAL NOTES:**

1. UNITS ARE SEALED WITH BUTYL TAPE AT THE JOINTS
2. DELIVERY IS MADE BY CRANE-EQUIPPED TRUCKS
3. EXCAVATION MUST BE READY, SAFE AND ACCESSIBLE FOR UNLOADING FROM THE REAR OF THE TRUCK.
4. MIN OVERHEAD CLEARANCE OF 18FT (5.5 METRES) IS REQUIRED
5. ALL UNITS MUST BE HANDLED WITH PROPER LIFTING EQUIPMENT
6. MAXIMUM BURIAL DEPTH = 1 METRE IN FIRM SOIL AWAY FROM ANY VEHICULAR TRAFFIC
7. MINIMUM BIONEST SECTION VOLUME TO BE: **4350L**  
CURRENT CAPACITY: **4375L**

**BST-2100-BCP SEPTIC TANK**

POS.	PART #	DESCRIPTION	QUANTITY
1	413562	BST-2100-BCP	1
2	408167	POLYLOK PLASTIC RISER 24"dia X 6'h	9
3	450027	POLYLOK LID 24"dia - DOMED	2
4	450046	POLYLOK LID 24"dia - VENTED LID	1
5	*SUPPLIED BY BIONEST*	FLEXIBLE AIR DIFFUSER (1m)	2
6	*SUPPLIED BY BIONEST*	AIR LINE PIPE	1
7	*SUPPLIED BY BIONEST*	BIONEST MEDIA BAG	12
8	112581	TUF-TITE EF-6" T-BAFFLE	2
9	408144	TUF-TITE EFFLUENT FILTER 6" C/W T-BAFF	1
10	112707	4 x 16" SOLID SEWER PIPE	3
11	408041	PVC TEE 4"	1
12	*SUPPLIED BY BIONEST*	Ø1-1/2" PVC ELBOW 90° BELL-END TO FACE UPWARD	2
13	*SUPPLIED BY BIONEST*	ABS PLASTIC STRIPS 5" x 24"	4
14	*SUPPLIED BY BIONEST*	AIR DIFFUSER CAGE 3.5' x 23"	4
15	106470	4" CAST IN COUPLER	1
16	112167	4" CAST A SEAL #452.0450	2
17	112167	4" CAST A SEAL #452.0450 (CLOSED FACE)	2
18	450103	POLYLOK 24" SAFETY LID	3

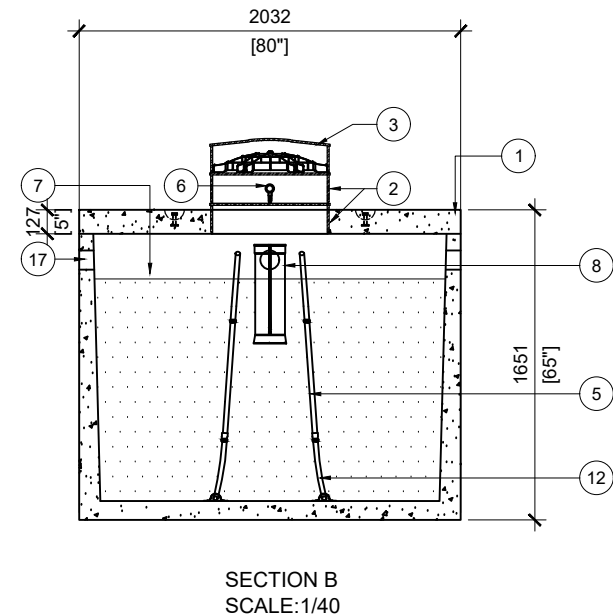
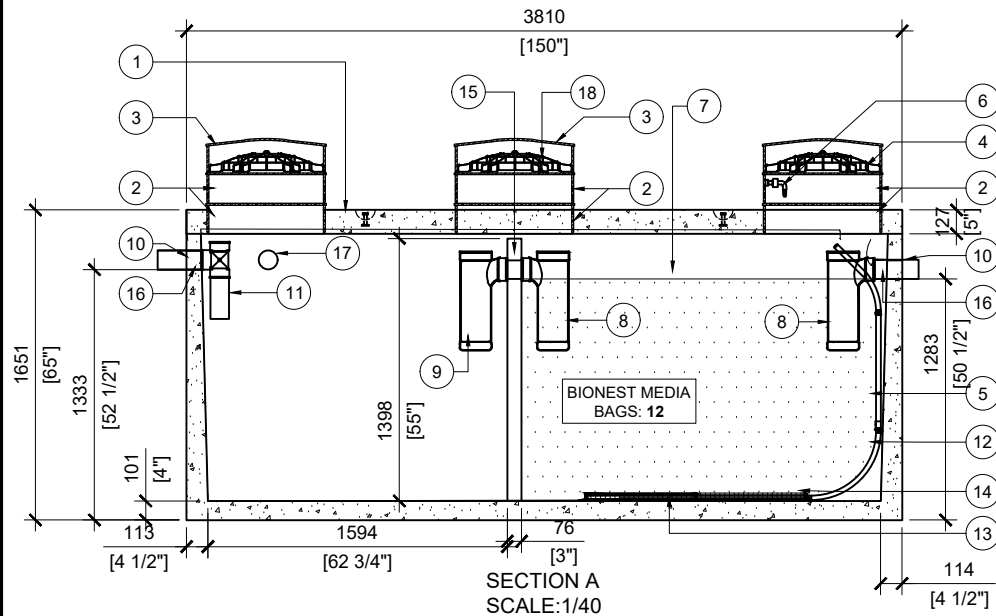

**MANUFACTURED:**  
LINDSAY, ON  
1-800-655-3430

**CONCRETE:** 35MPa at 28 days/5000PSI  
**AIR ENTRAINMENT:** 5-8%  
**REINFORCEMENT:** STEEL TO CSA CAN  
A23.1 /A23.3 G30.18 Fy=400MPa

**UNIT WEIGHT:** 18,885lbs / 8,566kg  
TANK: 12,538lbs / 6,141kg  
LID: 5,347lbs / 2,425kg  
MEETS CAN/CSA-B66  
BNQ CERTIFIED

**DRAWN BY:**  
SR

**DATE:**  
JAN/2024

**BST-2100-BCP**

7500L / 1650 IMPERIAL GAL. BIONEST TANK

**WORKING CAPACITY:** 7,577L TO INVERT OF OUTLET

**TOTAL CAPACITY:** 9,191L TO UNDERSIDE OF CHAMBER LID