

TOP VIEW
SCALE: 1/40

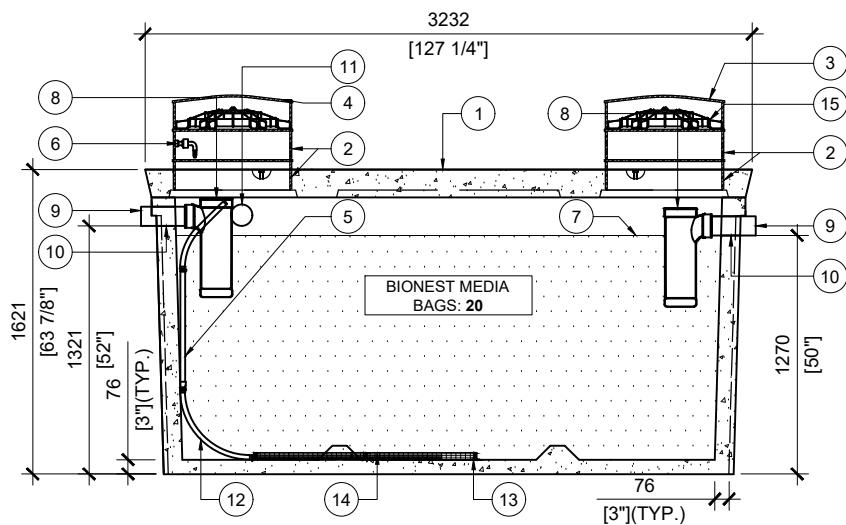

SECTION A
SCALE: 1/40

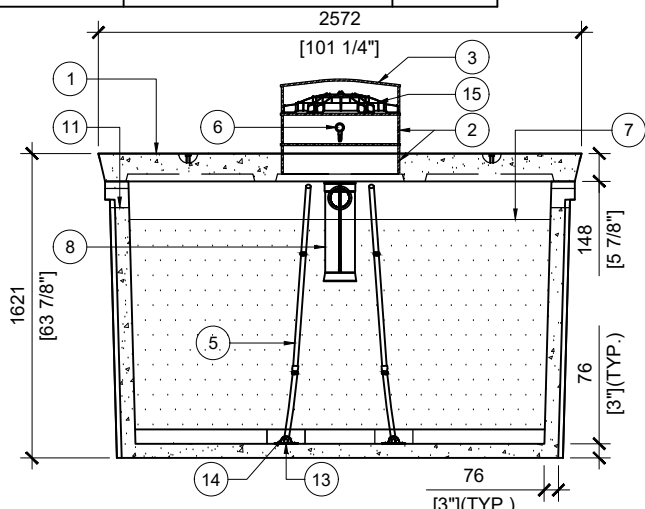

SECTION B
SCALE: 1/40

BTT-3400-BCP REACTOR

POS.	ITEM #	DESCRIPTION	QUANTITY
1	413573	BTT-3400-BCP BIONEST REACTOR	1
2	408167	POLYLOK PLASTIC RISER 24" dia X 6"h	6
3	450046	POLYLOK LID 24" dia - VENTED COVER	1
4	450046	POLYLOK LID 24" dia - DOMED	1
5	*SUPPLIED BY BIONEST*	FLEXIBLE AIR DIFFUSER (2 x 1m)	1
6	*SUPPLIED BY BIONEST*	AIR LINE PIPE / MANIFOLD 2 OUTLETS	1
7	*SUPPLIED BY BIONEST*	BIONEST MEDIA BAG	20
8	408144	TUF-TITE EF-6" T-BAFFLE	2
9	112707	4 x 16" SOLID SEWER PIPE	2
10	112167	4" CAST A. SEAL #452.0450	2
11	112622	4" CAST A. SEAL #452.0450 (CLOSED FACE)	2
12	*SUPPLIED BY BIONEST*	Ø1-1/2" PVC ELBOW 90° BELL-END TO FACE UPWARD	2
13	*SUPPLIED BY BIONEST*	ABS PLASTIC STRIPS 5" x 24"	4
14	*SUPPLIED BY BIONEST*	AIR DIFFUSER CAGE 3.5" x 23"	4
15	450103	POLYLOK 24" SAFETY LID	2

GENERAL NOTES:

1. UNITS ARE SEALED WITH BUTYL TAPE AT THE JOINTS
2. DELIVERY IS MADE BY CRANE-EQUIPPED TRUCKS
3. EXCAVATION MUST BE READY, SAFE AND ACCESSIBLE FOR UNLOADING FROM THE REAR OF THE TRUCK.
4. MIN OVERHEAD CLEARANCE OF 18FT (5.5 METRES) IS REQUIRED
5. ALL UNITS MUST BE HANDLED WITH PROPER LIFTING EQUIPMENT
6. MAXIMUM BURIAL DEPTH = 1 METRE IN FIRM SOIL AWAY FROM ANY VEHICULAR TRAFFIC