

TOP VIEW  
SCALE:1/40

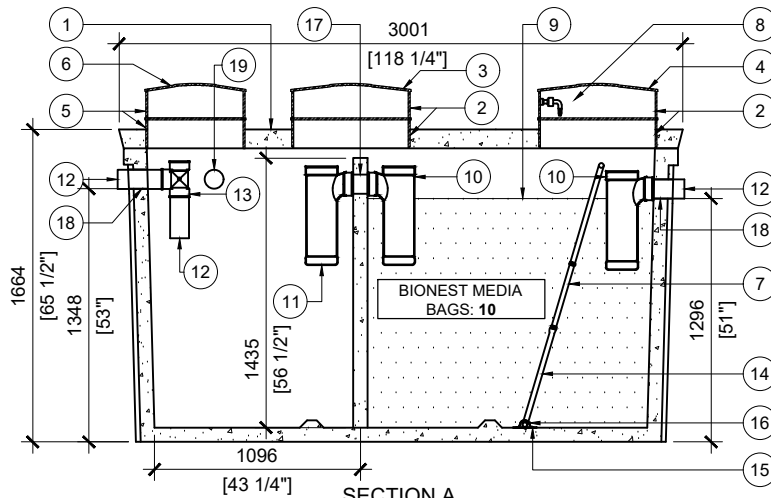

SECTION A  
SCALE:1/40

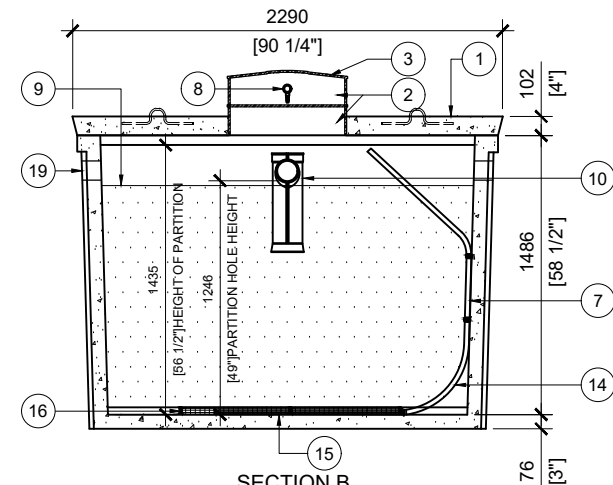

SECTION B  
SCALE:1/40

**GENERAL NOTES:**

1. UNITS ARE SEALED WITH BUTYL TAPE AT THE JOINTS
2. DELIVERY IS MADE BY CRANE-EQUIPPED TRUCKS
3. EXCAVATION MUST BE READY, SAFE AND ACCESSIBLE FOR UNLOADING FROM THE REAR OF THE TRUCK.
4. MIN OVERHEAD CLEARANCE OF 18FT (5.5 METRES) IS REQUIRED
5. ALL UNITS MUST BE HANDLED WITH PROPER LIFTING EQUIPMENT
6. MAXIMUM BURIAL DEPTH = 1 METRE IN FIRM SOIL AWAY FROM ANY VEHICULAR TRAFFIC
7. MINIMUM BIONEST SECTION VOLUME TO BE: **3520L**  
CURRENT CAPACITY: **3570L**

**BST-1700-BCP SEPTIC TANK**

POS.	PART #	DESCRIPTION	QUANTITY
1	413561	BST-1700-BCP	1
2	408167	POLYLOK PLASTIC RISER 24"dia X 6'h	4
3	450027	POLYLOK LID 24"dia - DOMED	1
4	450046	POLYLOK LID 24"dia - VENTED LID	1
5	450024	POLYLOK PLASTIC RISER 20"dia X 6'h	2
6	450025	POLYLOK LID 20"dia - DOMED	1
7	*SUPPLIED BY BIONEST*	FLEXIBLE AIR DIFFUSER (1m)	1
8	*SUPPLIED BY BIONEST*	AIR LINE PIPE	1
9	*SUPPLIED BY BIONEST*	BIONEST MEDIA BAG	10
10	112581	TUF-TITE EF-6" T-BAFFLE	2
11	408144	TUF-TITE EFFLUENT FILTER 6" C/W T-BAFF	1
12	106071	4 x 10" SOLID SEWER PIPE	3
13	408041	PVC TEE 4"	1
14	*SUPPLIED BY BIONEST*	Ø1-1/2" PVC ELBOW 90° BELL-END TO FACE UPWARD	1
15	*SUPPLIED BY BIONEST*	ABS PLASTIC STRIPS 5" x 24"	2
16	*SUPPLIED BY BIONEST*	AIR DIFFUSER CAGE 3.5" x 23"	2
17	106470	4" CAST IN COUPLER	1
18	112167	4" CAST A. SEAL #452.0450	2
19	112167	4" CAST A. SEAL #452.0450 (CLOSED FACE)	2



MANUFACTURED:  
BROOKLIN, ON  
1-800-655-3430

CONCRETE: 35MPa at 28 days/5000PSI  
AIR ENTRAINMENT: 5-8%  
REINFORCEMENT: STEEL TO CSA CAN  
A23.1/A23.3 G30.18 Fy=400MPa

UNIT WEIGHT: 13,400lbs / 6,080kg  
BNQ CERTIFIED  
MEETS CAN/CSA-B66

DRAWN BY:  
N.CHAN

DATE:  
APR/2020

**BST-1700-BCP**  
6135L / 1350 IMPERIAL GAL. BIONEST TANK

WORKING CAPACITY: 6,170L TO INVERT OF OUTLET  
TOTAL CAPACITY: 7,511L TO UNDERSIDE OF CHAMBER LID