

MAXIMUM FLOW RATE: 36L/min.
FOR THE SEPARATION OF OIL
AND GREASE.

GENERAL NOTES:

1. UNITS ARE SEALED WITH AN OIL RESISTANT BUTYL TAPE AT THE JOINTS (CONSEAL CS-440)
2. DELIVERY IS MADE BY CRANE-EQUIPPED TRUCKS
3. EXCAVATION MUST BE READY, SAFE AND ACCESSIBLE FOR UNLOADING FROM THE REAR OF THE TRUCK.
4. MIN OVERHEAD CLEARANCE OF 18FT (5.5 METRES) IS REQUIRED
5. ALL UNITS MUST BE HANDLED WITH PROPER LIFTING EQUIPMENT (I.E. SPREADER BAR)
6. MAXIMUM BURIAL DEPTH = 1 METRE IN FIRM SOIL AWAY FROM ANY VEHICULAR TRAFFIC
7. NOT INTENDED FOR STORMWATER APPLICATIONS.
8. CSA PERFORMANCE DATA PARAMETERS:
WATER = 23° (+/- 2°C)
OIL = 0.92 (+/- 0.01) SPECIFIC GRAVITY AT 20°C
9. 3" DIAMETER PVC PIPING FOR VENT 6 REQUIRED. ONLY 3 OPERATIONAL AT ONE TIME.

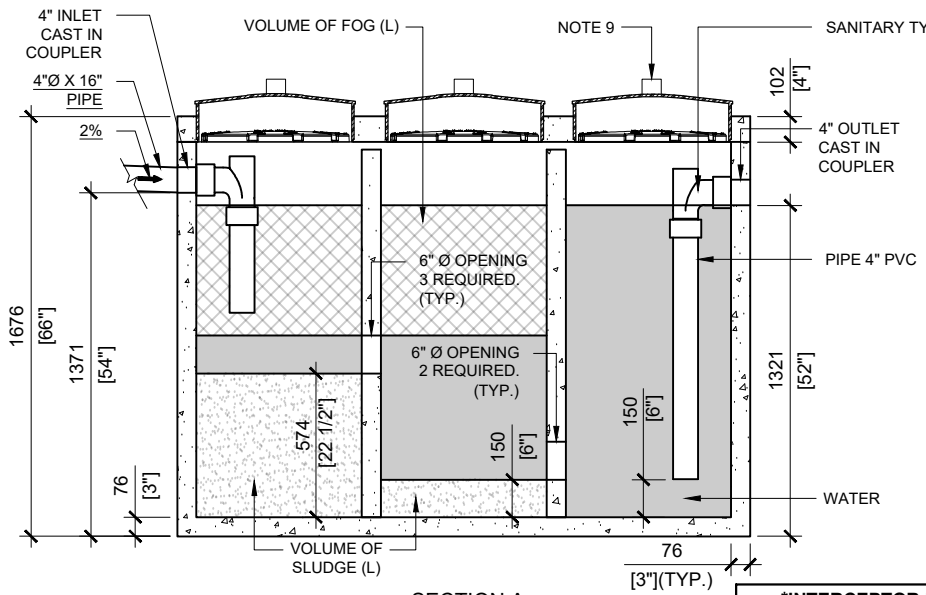

SECTION A
SCALE: 1/30

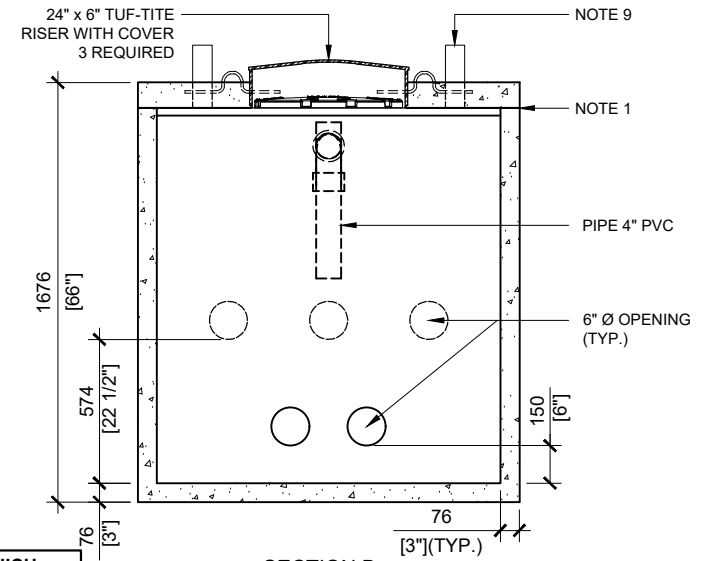

SECTION B
SCALE: 1/30

INTERCEPTOR UNITS FOR SYSTEMS WHICH CAPTURE PETROLEUM BASED PRODUCTS E.G. VEHICLE FUEL/OIL REQUIRE NITRILE RESISTANT COUPLERS FOR INSTALLATION WITH THE PVC PIPES TO PERMIT TANK SETTLING AND MOVEMENT



MANUFACTURED:
BROOKLIN, ON
1-800-655-3430

CONCRETE: 35MPa / 5,000PSI
AIR ENTRAINMENT: 5-8%
REINFORCEMENT : STEEL TO CSA CAN
A23.1 / A23.3. G30.18 Fy=400MPa

UNIT WEIGHT: 10,230lbs / 4,650kg
CPA CERTIFIED
MEETS CAN/CSA-B66
"AGINP"

DRAWN BY:
JAY PATEL

DATE:
APRIL/2022

MODEL 65 GREASE/OIL/SEDIMENT
INTERCEPTOR

3,000 LITRES
MAXIMUM FLOW RATE: 36 L/MINUTE