

**GENERAL NOTES:**

1. UNITS ARE SEALED WITH BUTYL TAPE AT THE JOINTS
2. DELIVERY IS MADE BY CRANE-EQUIPPED TRUCKS
3. EXCAVATION MUST BE READY, SAFE AND ACCESSIBLE FOR UNLOADING FROM THE REAR OF THE TRUCK.
4. MIN OVERHEAD CLEARANCE OF 18FT IS REQUIRED
5. ALL UNITS MUST BE HANDLED WITH PROPER LIFTING EQUIPMENT (I.E. SPREADER BAR)
6. MAXIMUM BURIAL DEPTH = 1 METRE IN FIRM SOIL AWAY FROM ANY VEHICULAR TRAFFIC

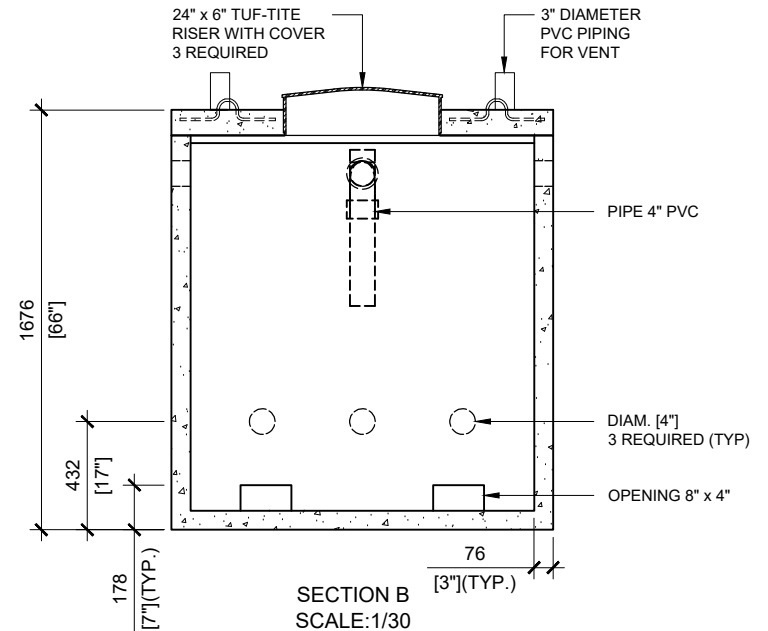
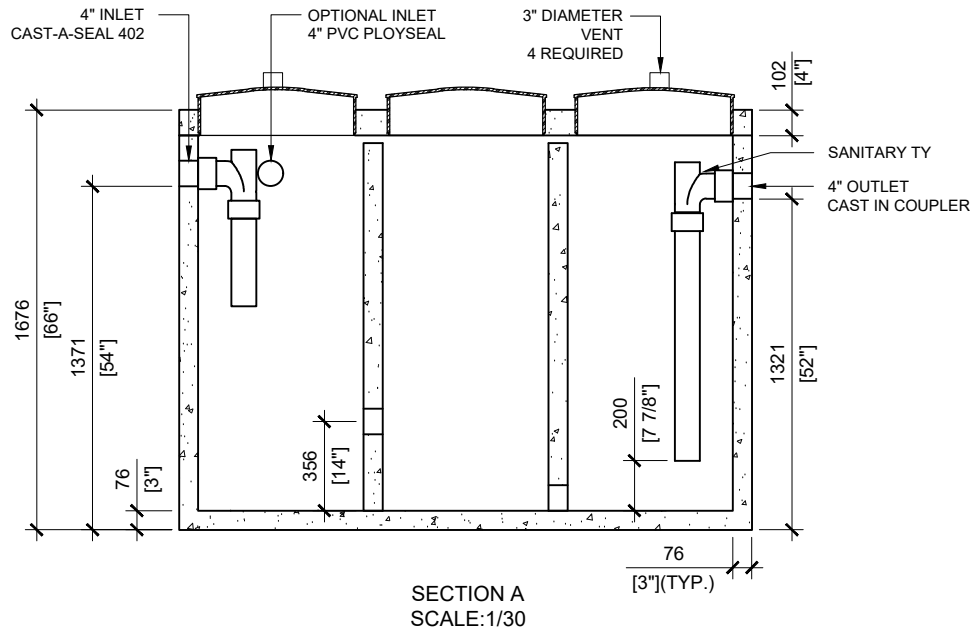

MANUFACTURED:  
BROOKLIN, ON  
1-800-655-3430

CONCRETE: 35MPa / 5,000PSI  
AIR ENTRAINMENT: 6-8%  
REINFORCEMENT : STEEL TO CSA CAN  
A23.1 / A23.3. G30.18 Fy=400MPa

UNIT WEIGHT: 10,230lbs / 4,650kg  
CPA CERTIFIED  
MEETS CAN/CSA-B66

DRAWN BY:  
S.RIMLAND  
DATE:  
JAN/2019

**MODEL 65** OIL INTERCEPTOR  
650 IMPERIAL GALLON / 3,000 LITRES  
OPTIMUM FLOW RATE: 36 L/MINUTE