

TOP VIEW
SCALE:1/30

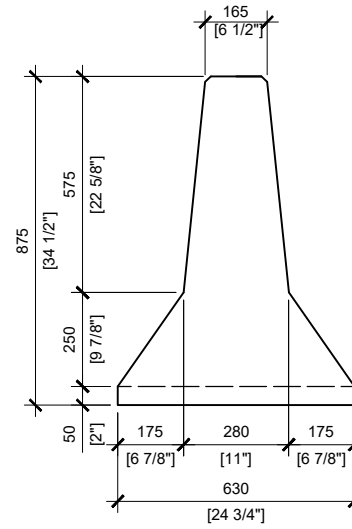

LEFT VIEW
SCALE:1/20

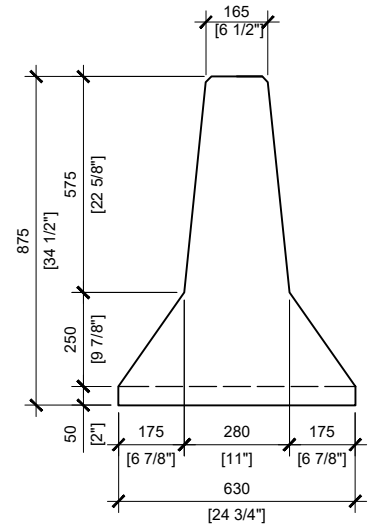

RIGHT VIEW
SCALE:1/20

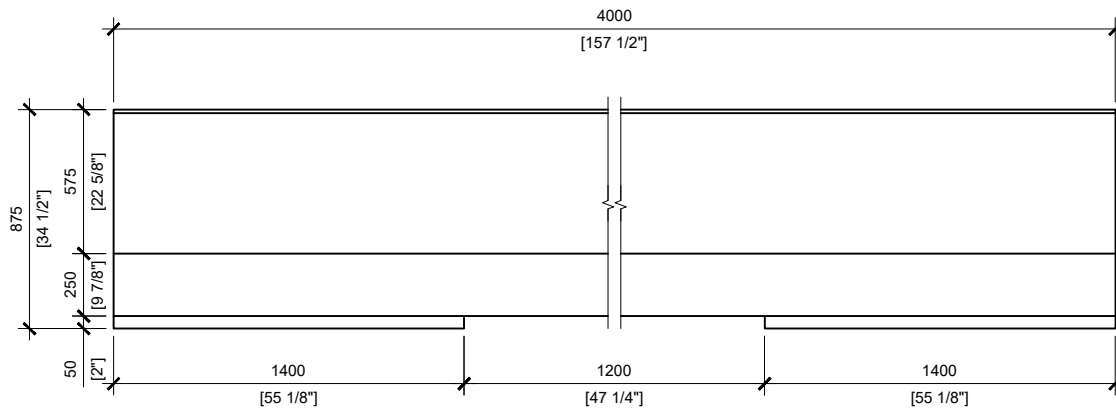

FRONT VIEW
SCALE:1/30

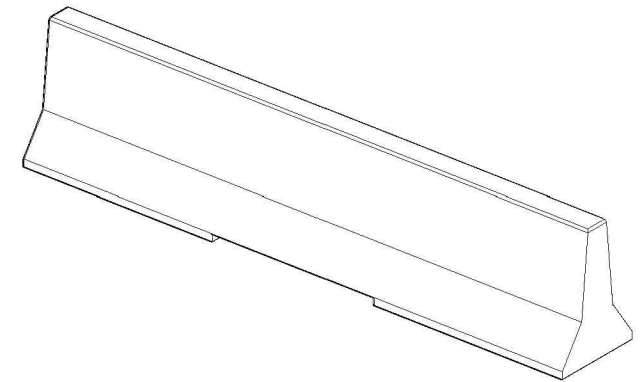

GENERAL NOTES:

1. ALL UNITS MUST BE HANDLE WITH PROPER LIFTING EQUIPMENT.
2. REINFORCING AND STIRRUPS SHALL BE SIZE 10M, GRADE 400W, DEFORMED STEEL BARS. CONCRETE COVER SHALL BE 50MM MINIMUM.
3. ALL CONCRETE EDGES SHALL HAVE 15X45° CHAMFER
4. WELDS SHALL BE ACCORDING TO CSA W59 AND CSA W186.
5. ALL DIMENSIONS ARE IN MILLIMETRES UNLESS OTHERWISE SHOWN.



MANUFACTURED:
OTTAWA, ON
613 822 1488

CONCRETE: 35MPa
AIR ENTRAINMENT: 5-8%
REINFORCEMENT : STEEL TO CSA CAN
A23.1 / A23.3 / A23.4. G30.18 Fy=400MPa

WEIGHT:
STANDARD MEDIAN BARRIER:
5,060lbs / 2,300kg

DRAWN BY:
S.RIMLAND

DATE:
OCT/2019

MEDIAN BARRIER

CONCRETE BARRIER PRECAST NO CONNECTION
4.0m LENGTH