

TOP VIEW
SCALE:1/40

GENERAL NOTES:

1. UNITS ARE SEALED WITH BUTYL TAPE AT THE JOINTS
2. DELIVERY IS MADE BY CRANE-EQUIPPED TRUCKS
3. EXCAVATION MUST BE READY, SAFE AND ACCESSIBLE FOR UNLOADING FROM THE REAR OF THE TRUCK.
4. MIN OVERHEAD CLEARANCE OF 18FT (5.5 METRES) IS REQUIRED
5. ALL UNITS MUST BE HANDLED WITH PROPER LIFTING EQUIPMENT (I.E. SPREADER BAR)
6. MAXIMUM BURIAL DEPTH = 1 METRE IN FIRM SOIL AWAY FROM ANY VEHICULAR TRAFFIC

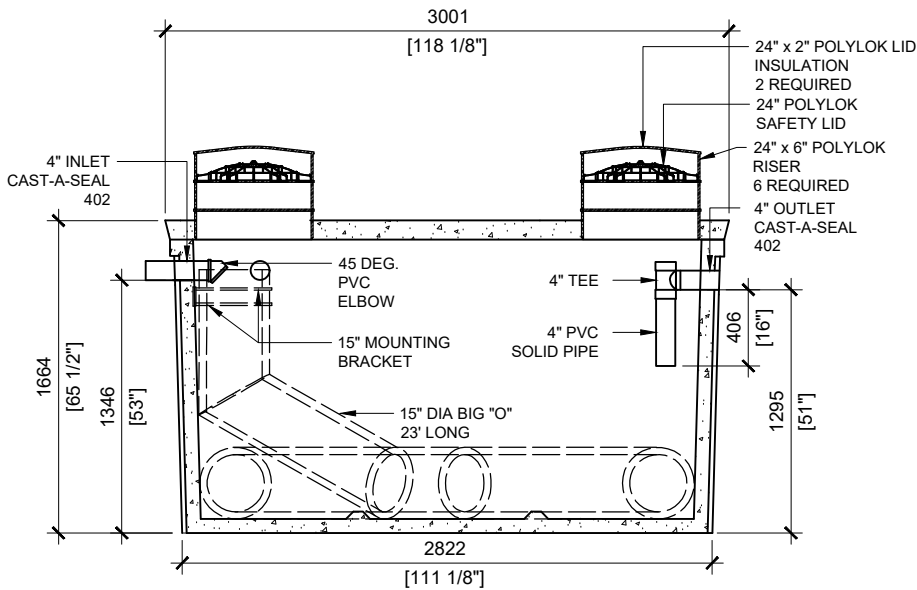

SECTION A
SCALE:1/40

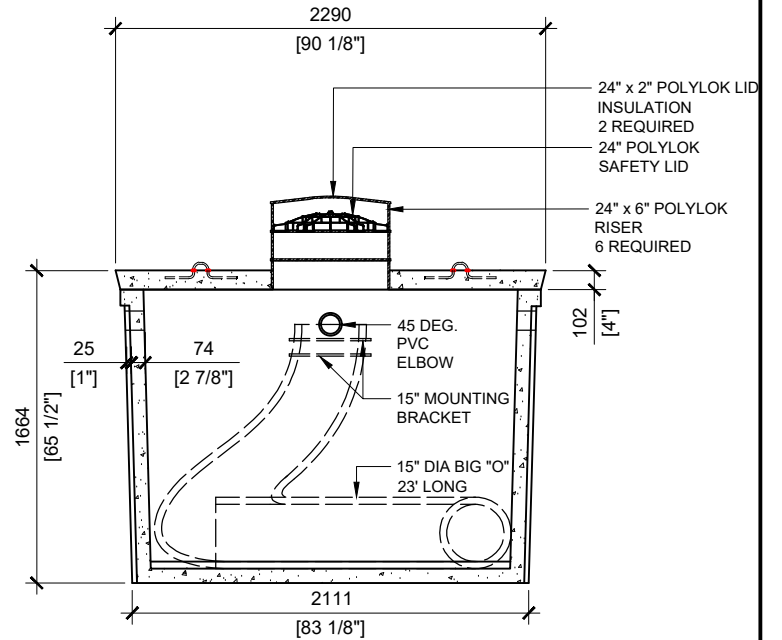

SECTION B
SCALE:1/40



MANUFACTURED:
BROOKLIN, ON
1-800-655-3430

CONCRETE: 35MPa/5000PSI
AIR ENTRAINMENT: 5-8%
REINFORCEMENT: STEEL TO CSA CAN
A23.1 /A23.3 G30.18 Fy=400MPa

UNIT WEIGHT: 13,400lbs / 6,078kg

DRAWN BY:
JAY PATEL

DATE:
JULY/2022

WATERLOO AD-6000

6,000 LITRES