

GENERAL NOTES:

1. UNITS ARE SEALED WITH BUTYL TAPE AT THE JOINTS
2. DELIVERY IS MADE BY CRANE-EQUIPPED TRUCKS
3. EXCAVATION MUST BE READY, SAFE AND ACCESSIBLE FOR UNLOADING FROM THE REAR OF THE TRUCK.
4. MIN OVERHEAD CLEARANCE OF 18FT (5.5 METRES) IS REQUIRED
5. ALL UNITS MUST BE HANDLED WITH PROPER LIFTING EQUIPMENT (I.E. SPREADER BAR)
6. SCHEMATIC ONLY (FURTHER DETAIL UPON REQUEST)
7. THREADED COVER TO BE REMOVED AND REPLACED BY INTERNAL PUMP CHAMBER (PROVIDED BY WATERLOO) ON SITE
8. MAXIMUM BURIAL DEPTH = 1 METRE IN FIRM SOIL AWAY FROM ANY VEHICULAR TRAFFIC

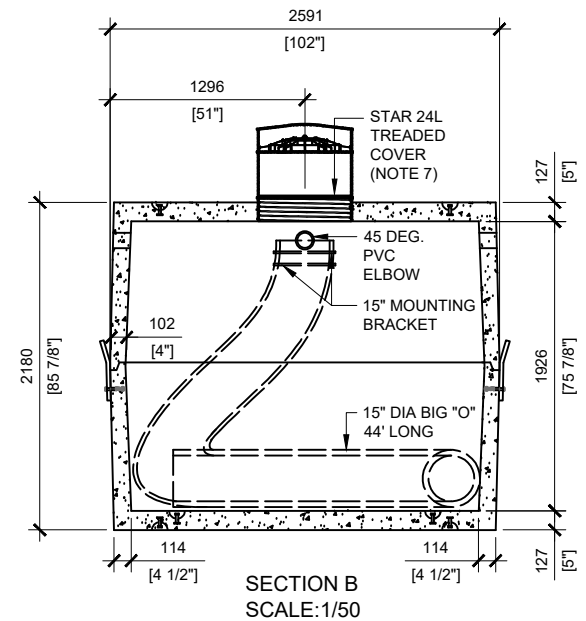
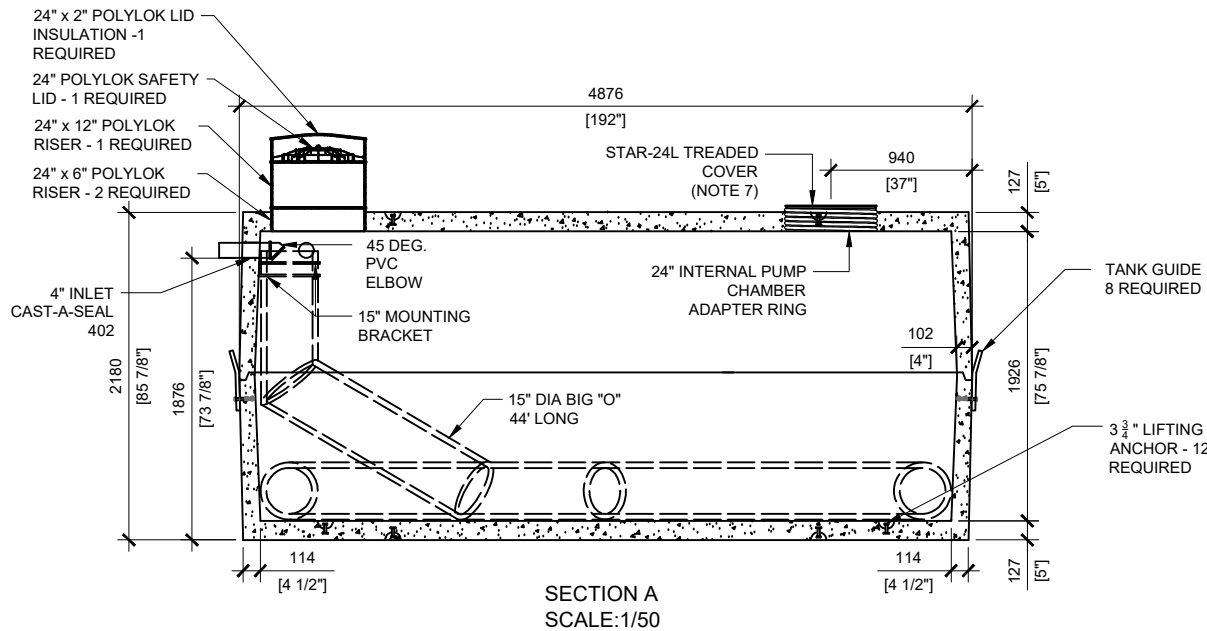

MANUFACTURED:
LINDSAY, ON
1-800-655-3430

CONCRETE TYPE: SCC
CONCRETE: 45MPa at 28 days / 6,500PSI
AIR ENTRAINMENT: 5-8%
REINFORCEMENT: STEEL TO CSA CAN
A23.1 /A23.3 G30.18 Fy=400MPa

WEIGHT:
BOTTOM - 17,712lbs / 8,050kg
TOP - 17,571lbs / 7,989kg

DRAWN BY:
PRASHAN

DATE:
DEC/2023

WATERLOO ADIPC-18000

18,000 LITRES