

**GENERAL NOTES:**

1. UNITS ARE SEALED WITH BUTYL TAPE AT THE JOINTS
2. DELIVERY IS MADE BY CRANE-EQUIPPED TRUCKS
3. EXCAVATION MUST BE READY, SAFE AND ACCESSIBLE FOR UNLOADING FROM THE REAR OF THE TRUCK.
4. MIN OVERHEAD CLEARANCE OF 18FT (5.5 METRES) IS REQUIRED
5. ALL UNITS MUST BE HANDLED WITH PROPER LIFTING EQUIPMENT (I.E. SPREADER BAR)
6. MAXIMUM BURIAL DEPTH = 1 METRE IN FIRM SOIL AWAY FROM ANY VEHICULAR TRAFFIC

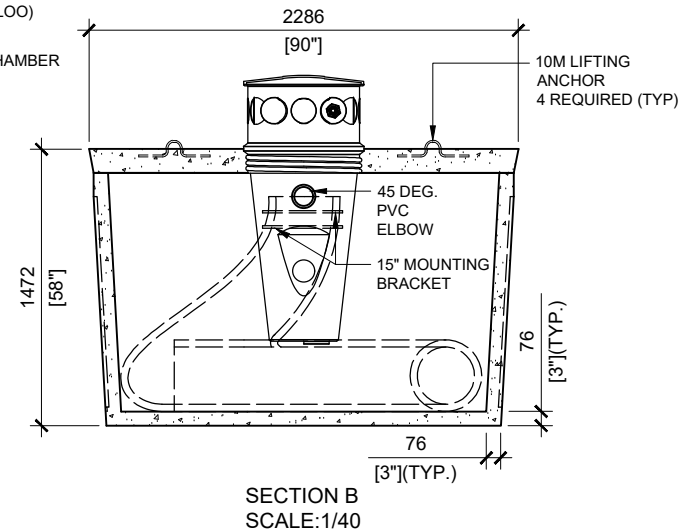
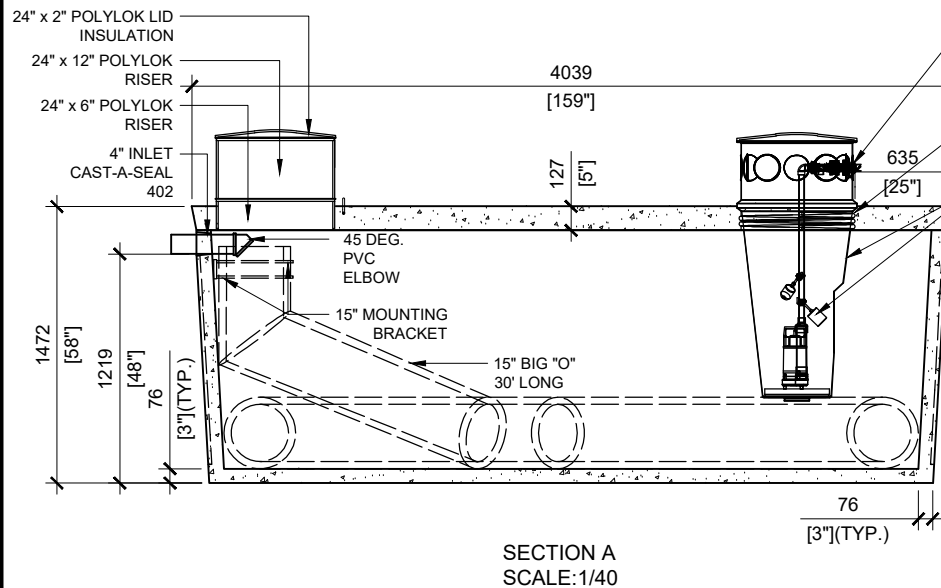

MANUFACTURED:  
BROOKLIN, ON  
1-800-655-3430

CONCRETE: 35MPa/5000PSI  
AIR ENTRAINMENT: 6-8%  
REINFORCEMENT: STEEL TO CSA CAN  
A23.1 / A23.3 G30.18 Fy=400MPa

WEIGHT: 16,050lbs / 7,280kg  
CPA CERTIFIED  
MEETS CSA-BB6-00

DRAWN BY:  
N.CHAN  
DATE:  
MAR/2020

**WATERLOO ADIPC-9000 LOW**  
2,000 IMPERIAL GALLON / 9,000 LITRES