

GENERAL NOTES:

1. UNITS ARE SEALED WITH BUTYL TAPE AT THE JOINTS
2. DELIVERY IS MADE BY CRANE-EQUIPPED TRUCKS
3. EXCAVATION MUST BE READY, SAFE AND ACCESSIBLE FOR UNLOADING FROM THE REAR OF THE TRUCK.
4. MIN OVERHEAD CLEARANCE OF 18FT IS REQUIRED
5. ALL UNITS MUST BE HANDLED WITH PROPER LIFTING EQUIPMENT
6. MAXIMUM BURIAL DEPTH = 1 METRE IN FIRM SOIL AWAY FROM ANY VEHICULAR TRAFFIC
7. CENTER PIPE MANIFOLD LENGTH 57-1/4"

TOP VIEW
SCALE: 1/50

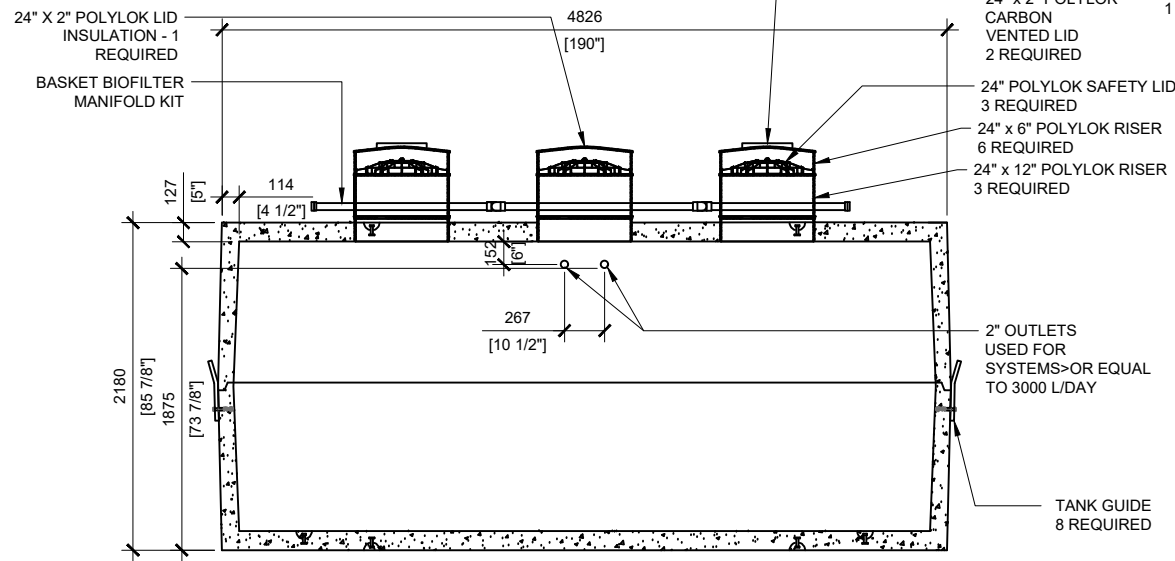

SECTION A
SCALE: 1/50

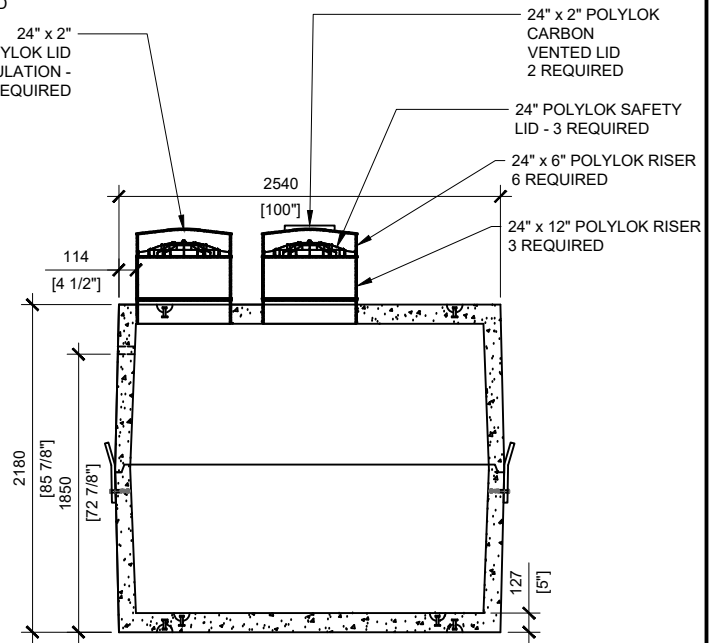

SECTION B
SCALE: 1/50



MANUFACTURED:
LINDSAY, ON
1-800-655-3430

CONCRETE: 35MPa at 28 days / 5000PSI
AIR ENTRAINMENT: 5-8%
REINFORCEMENT: STEEL TO CSA CAN
A23.1 / A23.3 G30.18 Fy=400MPa

WEIGHT:
BOTTOM - 17,712lbs / 8,050kg
TOP - 17,571lbs / 7,989kg

DRAWN BY:
PRASHAN

DATE:
DEC/2023

WATERLOO BT-18000

18,000 LITRES