

**GENERAL NOTES:**

1. UNITS ARE SEALED WITH BUTYL TAPE AT THE JOINTS
2. DELIVERY IS MADE BY CRANE-EQUIPPED TRUCKS
3. EXCAVATION MUST BE READY, SAFE AND ACCESSIBLE FOR UNLOADING FROM THE REAR OF THE TRUCK.
4. MIN OVERHEAD CLEARANCE OF 18FT (5.5 METRES) IS REQUIRED
5. ALL UNITS MUST BE HANDLED WITH PROPER LIFTING EQUIPMENT
6. MAXIMUM BURIAL DEPTH = 1 METRE IN FIRM SOIL AWAY FROM ANY VEHICULAR TRAFFIC
7. TUF-TITE SAFETY LID INSTALLED IN OPENING AS PER CSA-B66-21

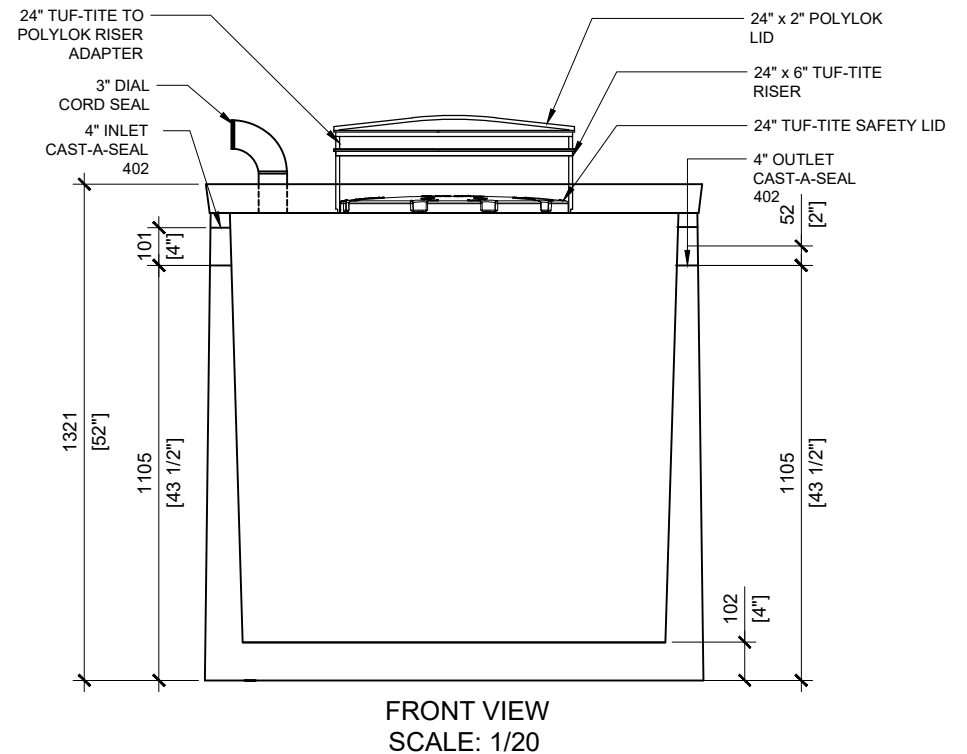
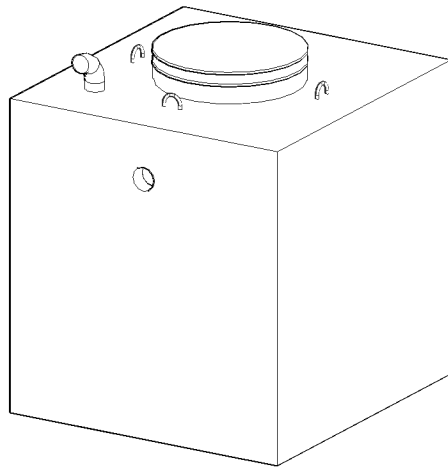

MANUFACTURED:  
BROOKLIN, ON  
1-800-655-3430

CONCRETE: 35MPa/5000PSI  
AIR ENTRAINMENT: 5-8%  
REINFORCEMENT: STEEL TO CSA CAN  
A23.1 /A23.3 G30.18 Fy=400MPa

WEIGHT:  
1200 LITRES- 3,560 lbs / 1,615kg

DRAWN BY:  
JAY PATEL

DATE:  
AUG/2022

**WATERLOO PT-1200**

1200 LITRES